



atmosphere is everything

14716 S. Broadway • Gardena, CA 90248 • USA
 TEL: (310) 532-1555 • (800) 421-1266 • FAX: (310) 324-3030
 Web Site: www.marsair.com • E-mail: info@marsair.com

PROJECT		OPTIONS/ITEMS	
TITLE			
COMMENTS		DATE 4/3/15	PAGE
		REV. NO	
MODEL NO. HV2 Series	DRAWING NO HV2HWS-F	DRAWN BY TVN	CHECKED BY
		FILE NAME	

Hot Water/Steam Heated Drawing

HV2 (High Velocity 2 Series)

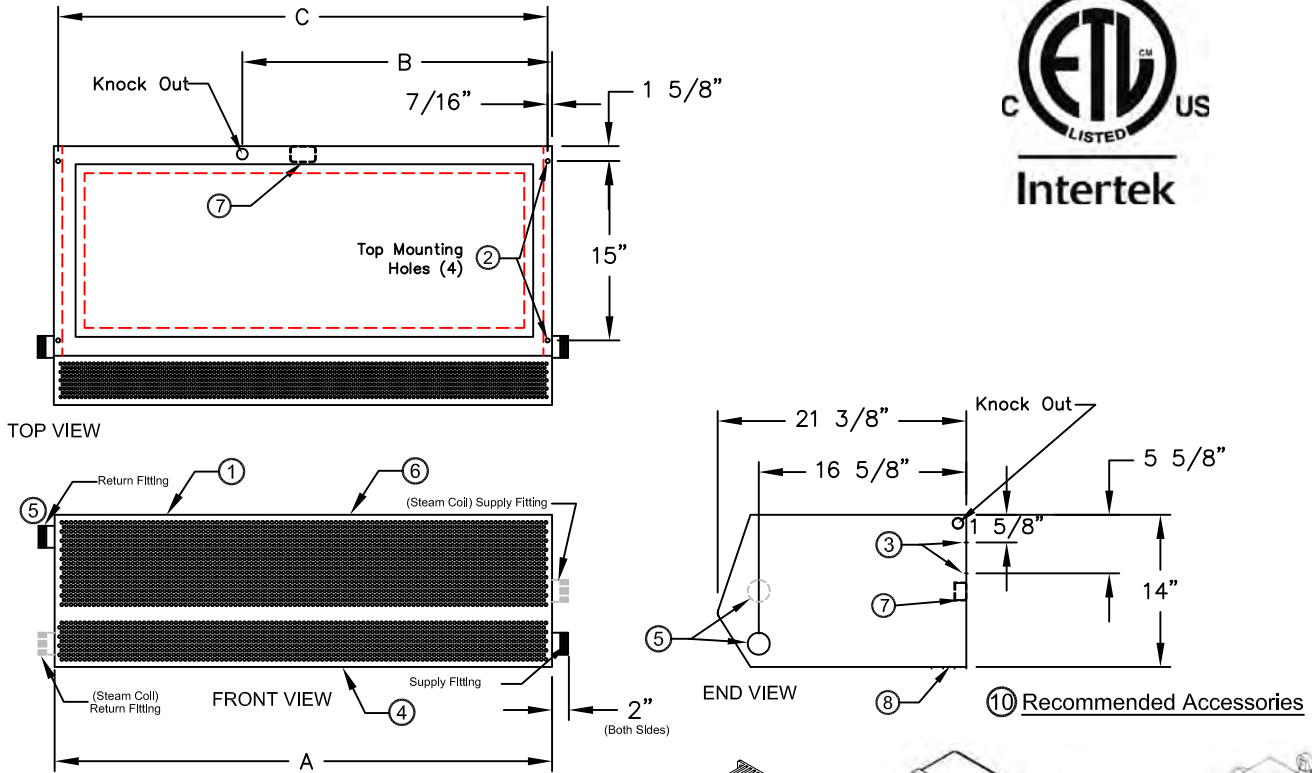

*- Use corresponding letters in "Coil Data" then "Electrical Data" columns to complete the model numbers.

Note: MARS reserves the right to change specifications and product design without notice. Such revisions do not entitle the buyer to corresponding changes, improvements additions or replacements for previously purchased equipment.

Notes:

Variable Frequency Drive Control Panels with Remote T'stat (9)

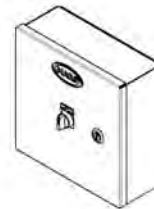
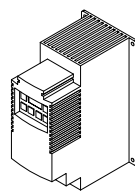

Door Limit Switches

MODEL NUMBER	OVERALL LENGTH A (In)	KNOCKOUT LOCATION B (In)	REAR MOUNTING CENTER C (in)	CONN. DIA (in)
HV248-1**-TS	48	31 1/2	47 1/8	1 1/2 MPT
HV260-1**-TS	60	37 1/2	59 1/8	1 1/2 MPT
HV272-2**-TS	72	40	71 1/8	1 1/2 MPT
HV284-2**-TS	84	46	83 1/8	1 1/2 MPT
HV296-2**-TS	96	52	95 1/8	1 1/2 MPT
HV2108-3**-TS	108	58	107 1/8	1 1/2 MPT
HV2120-2**-TS	120	64	119 1/8	1 1/2 MPT
HV2120-3**-TS	120	64	119 1/8	1 1/2 MPT
HV2144-3**-TS	144	76	143 1/8	1 1/2 MPT

- This product is designed to meet the National Electric Code (NEC) and is ETL listed for the US and Canada (UL 1995 and CSA 22.2).
- (4) 7/16" mounting holes provided on for overhead mounting provided, (2) on each end.
- (2) 1/2" key hole slots and (2) 7/16" mounting holes are provided on each end of the back side for wall mounting.
- All units have a self contained one piece cabinet, fire retardant and corrosion proof paint lock metal double protected with baked on Titanium Silver color, rust preventative electrostatic polyurethane powder coating.
- Hot Water application shown. For Steam, return fitting is at bottom of manifold and supply is at center of manifold.
- Cabinet is to be mounted from overhead or fastened to a wall and has sufficient strength for suspension from both ends without intermediate support.
- Internal J-Box(es) for electrical wiring are provided.
- Unit is to be installed such that air flow is unobstructed. Unit has a 3" air discharge nozzle containing adjustable air directional vanes with 40° sweep front to back.
- Circuit protection as per NEC by others.
- Optional motor control panel, door limit switch and mounting brackets are field installed and/or wired by others. The door limit switch is to be mounted such that the air curtain turns on as door begins to open. To prevent unit damage, the mounting brackets must be installed such that the bottom of the air curtain is not below the door header.

HV2 (High Velocity 2) Series

Hot Water/Steam Heated

Model Lengths 48" – 144"



atmosphere is everything

14716 S. BROADWAY, GARDENA, CA 90248 • Ph: (310) 532-1555 Fax: (310) 532-3030 • www.marsair.com
 © Copyright Mars Air Systems, LLC 2014

Hot Water/Steam Heated Data Sheet

Applications: Environmental Separation: Max Height 14' / Insect Control: Max Height 12'

HV2 (High Velocity) Series 2 Model Number	Mechanical Data						Lab Data				
	Nozzle Length (in)	Length (in)	Depth (in)	Height (in)	Motor (hp)	Weight (lbs)	Max Core Velocity at Nozzle (fpm)	Avg Velocity (fpm)	Volume (cfm)	Uniformity (%)	Power Rating (watts)
HV248-1**-TS	48	52	21.5	14	1	165	6144	2447	2447	88	1360
HV260-1**-TS	60	64	21.5	14	1	190	6330	2208	2760	80	1560
HV272-2**-TS	72	76	21.5	14	Two 1	280	5722	2389	3584	92	1930
HV284-2**-TS	84	88	21.5	14	Two 1	300	6051	2654	4644	93	2610
HV296-2**-TS	96	100	21.5	14	Two 1	325	6144	2447	4894	88	2720
HV2108-3**-TS	108	112	21.5	14	Three 1	400	5722	2389	5376	92	2895
HV2120-2**-TS	120	124	21.5	14	Two 1	385	6330	2208	5519	80	3120
HV2120-3**-TS	120	124	21.5	14	Three 1	440	6060	2678	6693	93	3615
HV2144-3**-TS	144	148	21.5	14	Three 1	500	6144	2447	7341	88	4080

* - Use corresponding letters in "Coil Data" then "Electrical Data" columns to complete the model numbers.

Note: Data above for 1725 RPM at 60 Hz, 50 Hz is 1425 RPM with a 17% reduction in the performance data.

Features:

Air Curtain

- ❖ 1 HP Continuous Duty TEAO Motors
- ❖ Sleek self-contained one piece heavy gauge corrosion proof paint lock metal design
- ❖ ETL Certified to conform to UL 1995 (US) and CSA 22.2 (Canada) Standards
- ❖ Cabinet has sufficient strength for fastening to wall on both ends without intermediate support.
- ❖ Adjustable air directional vanes with 40° sweep front to back
- ❖ Standard color is Titanium Silver
- ❖ Rust preventative electrostatic polyurethane powder coating
- ❖ 18 months parts warranty
- ❖ Freight FOB the factory
- ❖ Proudly Made in the USA

Hot Water and Steam Coils

- ❖ Coil casings shall not be less than 16 gauge galvanized steel with tube holes formed with extruded collars.
- ❖ Fins are die formed .006" aluminum (1 row – 10 FPI, 2 row – 8 FPI)
- ❖ Coils tubes constructed of heavy wall, 5/8" OD seamless copper (Steam - .035" & Hot Water - .025")
- ❖ Coil tubes arranged in a staggered pattern and mechanically expanded into fins to ensure a uniform pressure bond
- ❖ Manifolds shall be of heavy seamless copper construction
- ❖ All joints shall be brazed with high temperature silver brazing alloy (Steam – 7% & Hot Water – 3%), max steam operating pressure: 30 PSI
- ❖ Fittings shall be of wrought copper or similar construction such that the entire fluid circuit shall be of compatible nonferrous materials.
- ❖ Manifold shall be fitted with 1/4" vent or drain fittings
- ❖ Supply fitting is on the right side of coil. Return fitting is on the left side

Options and Accessories: (see Accessories Brochure)

- ❖ Motor Control Panels with remote mounted t'stat
- ❖ Steam distribution, Cupro Nickel and CRN coils
- ❖ Rust resistant epoxy coated or SS coils
- ❖ Custom housing and transition colors and finishes (304SS, 316SS)

Sound Levels: (measured at 10' in an open field)

1 Motor Unit = 70 dBA, 2 Motor Unit = 73 dBA, 3 & 4 Motor Unit = 75 dBA

Coil Data	Hot Water				Steam		
	Coil Code (X)	GPM	MBH	Temp Rise (°F)	Coil Code (Y)	MBH	Temp Rise (°F)
HV248-1**-TS	2 Row	16	96	37	1 Row	91	35
HV260-1**-TS	2 Row	14	115	39	1 Row	112	38
HV272-2**-TS	2 Row	19	154	40	1 Row	143	37
HV284-2**-TS	2 Row	15	175	35	1 Row	178	36
HV296-2**-TS	2 Row	15	194	37	1 Row	198	37
HV2108-3**-TS	2 Row	16	219	38	1 Row	221	38
HV2120-2**-TS	2 Row	15	230	39	1 Row	237	40
HV2120-3**-TS	2 Row	16	249	35	1 Row	263	36
HV2144-3**-TS	2 Row	14	275	35	1 Row	304	38

EAT: 70 F, EWT: 200 F, Steam pressure: 5 PSI

Electrical Data (FLA)	Unit Voltage (Voltage Code)				
	115v (A)	208/230v/10 (D)	208/230v/30 (G)	460v (H)	575v (I)
HV248-1**-TS	9.0	5.0	3.3/3.2	1.6	1.3
HV260-1**-TS	9.0	5.0	3.3/3.2	1.6	1.3
HV272-2**-TS	18.0	10.0	6.6/6.4	3.2	2.6
HV284-2**-TS	18.0	10.0	6.6/6.4	3.2	2.6
HV296-2**-TS	18.0	10.0	6.6/6.4	3.2	2.6
HV2108-3**-TS	27.0	15.0	9.9/9.6	4.8	3.9
HV2120-2**-TS	18.0	10.0	6.6/6.4	3.2	2.6
HV2120-3**-TS	27.0	15.0	9.9/9.6	4.8	3.9
HV2144-3**-TS	27.0	15.0	9.9/9.6	4.8	3.9

* - Use corresponding letters in "Electrical Data" columns to complete the model numbers.

Note: For Ampacity Multiply FLA X 1.25

EXAMPLE

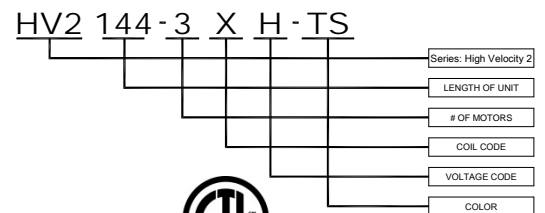

NOTE: MARS AIR SYSTEMS, LLC reserves the right to change specifications and product design without notice. Such revisions do not entitle the buyer to corresponding changes, improvements, additions or replacements for previously purchased equipment.