



atmosphere is everything

14716 S. Broadway • Gardena, CA 90248 • USA
 TEL: (310) 532-1555 • (800) 421-1266 • FAX: (310) 324-3030
 Web Site: www.marsair.com • E-mail: info@marsair.com

PROJECT		OPTIONS/ITEMS	
TITLE			
COMMENTS		DATE 4/17/15	PAGE
		REV. NO	
MODEL NO. BD18 Series	DRAWING NO. BD18E-F	DRAWN BY TVN	CHECKED BY
		FILE NAME	

Electric Heated Drawing

BD18 (Belt Driven 18) Series

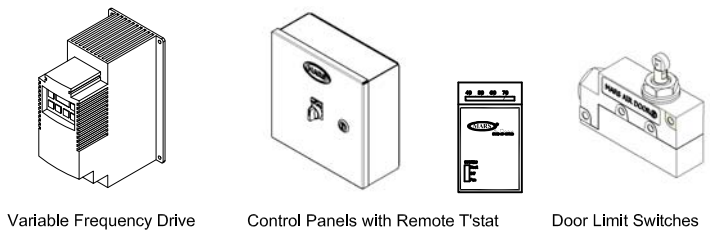
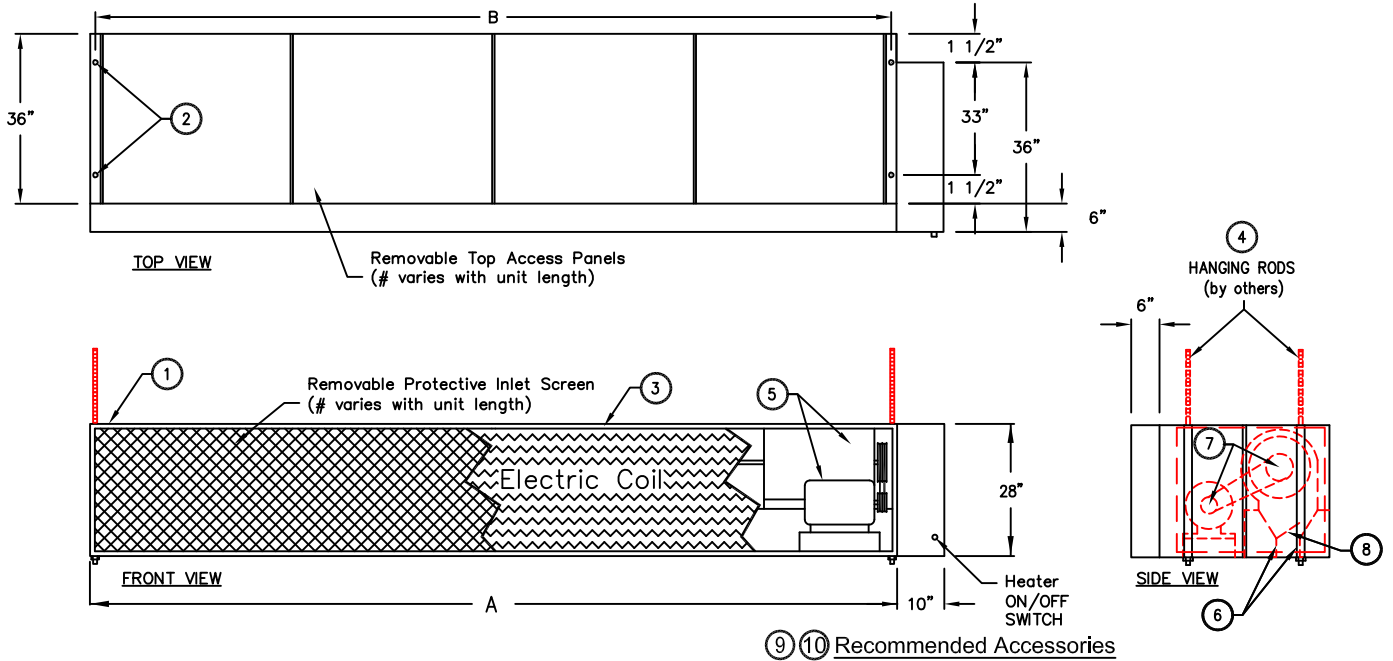

*- Use corresponding letters in "Electrical Data" columns to complete the model numbers.

MODEL NUMBER	NOZZLE LENGTH (in)	OVERALL LENGTH A (in)	MOUNTING WIDTH B (in)
BD1896-1E*-TS	96	107	105 1/2
BD18120-1E*-TS	120	131	129 1/2
BD18144-1E*-TS	144	155	153 1/2
BD18168-1E*-TS	168	179	177 1/2
BD18192-1E*-TS	192	203	201 1/2

Notes:

- This product is designed to meet the National Electric Code (NEC) and is CSA Listed.
- (4) 5/8" mounting holes provided on for overhead mounting provided, (2) on each end.
- All units have a self contained one piece cabinet, fire retardant and corrosion proof paint lock metal double protected with baked on Titanium Silver color, rust preventative electrostatic polyurethane powder coating.
- Cabinet is to be mounted from overhead and has sufficient strength for suspension from both ends without intermediate support.
- Unit is to be installed such that air flow is unobstructed. Unit has a 4.5" air discharge nozzle containing adjustable air directional vanes with 40° sweep front to back. To prevent unit damage, the air curtain must be installed such that the bottom of the air curtain is not below the door header.
- Units are direct drive. One external top mounted 2"x4" J-box provided above each motor.
- Electric heater shown with heater component panel on right side, as standard. (Note: This is not the same as the optional remote air curtain unit control panel, see note 10.) Optional left hand mounting available. Special remote mounted heater component panel available for installations with space limitations. Contact factory for details and minimum installation space requirements.
- Wall mounted 24 volt thermostat with remote "heat/off/fan" switch is shipped loose and field installed. Terminal block provided inside control panel.
- Circuit protection as per NEC by others.
- Optional remote air curtain unit control panel and door limit switch are field installed and wired by others. The remote air curtain unit control panel is required when a door limit switch is used to automatically turn the air curtain on as door begins to open. Special remote mounted heater component panel (see note 7) is integrated with the optional remote air curtain unit control panel when the two options are selected.

BD18 (Belt Drive) Series

Electric Heated

Model Lengths 96" – 192"



atmosphere is everything

14716 S. BROADWAY, GARDENA, CA 90248 • Ph: (310) 532-1555 Fax: (310) 532-3030 • www.marsair.com
© Copyright Mars Air Systems, LLC 2014

Electric Heated Data Sheet

Applications: Environmental Separation: Max Height 20' / Insect Control: Max Height 18'

BD18 (WindGuard)	Mechanical Data						Lab Data	
Model Number	Nozzle Length (in)	Length (in)	Depth (in)	Height (in)	Motor (hp)	Weight (lbs)	Max Velocity (fpm)	Max Volume (cfm)
BD1896-1E*-TS	96	107	42	28	7 1/2	800	5100	13800
BD18120-1E*-TS	120	131	42	28	7 1/2	925	5100	17255
BD18144-1E*-TS	144	155	42	28	10	1050	5100	20700
BD18168-1E*-TS	168	179	42	28	10	1175	5100	24100
BD18192-1E*-TS	192	203	42	28	15	1300	5100	27600

* - Use corresponding letters in "Electrical Data" columns to complete the model numbers.

Note: Data above is for 60 Hz, 17% reduction in the performance data with 50 Hz.

Features:

- Air Curtain
- 7 ½ to 15 HP Heavy Duty TEFC Motors
- Air curtain has a self-contained cabinet with sufficient strength for fastening from overhead on both ends without intermediate support. Top and rear mounting holes provided (4) 3/4"
- Adjustable air directional nozzle with 40° sweep front to back
- Standard color is Titanium Silver
- Rust preventative electrostatic polyurethane powder coating
- All units are shipped fully assembled ready for installation
- 12 month parts warranty
- Freight Not Included (FOB Factory)
- Proudly Made in the USA

Electric Heater Coil and Wiring

- Coils are an open type for rapid temperature rise to be located in the air curtain's intake directly in the air stream.
- Manual reset thermal overload protection provided
- Controls are externally mounted, prewired ready for power connection
- A heat ON/OFF switch is unit mounted on external controls

Mars Recommended Accessories (See Submittals for additional details):

- Door Limit Switches
 - 99-125, Industrial surface mounted magnetic switch (controller required)
 - Controllers
 - MCP*-†E*, Motor Control Panel, 120V control voltage (* = HP Code [G for 7.5 HP, H for 10 HP, I for 15 HP], † = # of Motors, * = Voltage Code)
 - MCP-TD, Adjustable time delay, 1sec-100hr (panel required)
 - MCP-24V, Low voltage control option (panel required)
 - BMS-306, BMS for monitor and control (panel required with MCP-24V)
- Note: Dry contact provided in panel for monitoring motor. 24Vac signal provided from panel for controlling motor

Sound Levels: (measured at 10' in an open field)

7 ½ HP Motor Unit = 74 dBA, 10 HP Motor Unit = 75 dBA, 15 HP Motor Unit = 76 dBA

Electrical Data (FLA)	Heater Voltage (Voltage Code) Amperage		Heater Data	
	460v (H)	575v (I)	3Ø kW	Temp Rise (°F)
BD1896-1E*-TS	164	131	130	30
BD18120-1E*-TS	208	166	165	30
BD18144-1E*-TS	245	196	195	30
BD18168-1E*-TS	289	231	230	30
BD18192-1E*-TS	327	262	260	30

* - Use corresponding letters in "Electrical Data" columns to complete the model numbers.

Note: For Ampacity Multiply FLA X 1.25

Model Number	Motor Amperage	
	460v/3Ø (H)	575v/3Ø (I)
BD1896-1E*-TS	10.0	8.9
BD18120-1E*-TS	10.0	8.9
BD18144-1E*-TS	13.0	10.3
BD18168-1E*-TS	13.0	10.3
BD18192-1E*-TS	20.0	15.6

* - Use corresponding letters in "Electrical Data" columns to complete the model numbers.

Note: For Ampacity Multiply FLA X 1.25

EXAMPLE

BD18 96 - 1 E H - TS

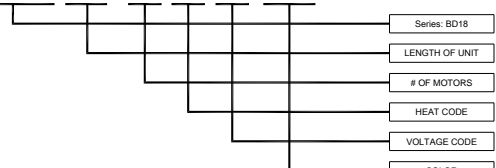

NOTE: MARS AIR SYSTEMS, LLC reserves the right to change specifications and product design without notice. Such revisions do not entitle the buyer to corresponding changes, improvements, additions, or replacements for previously purchased equipment.