



atmosphere is everything

14716 S. Broadway • Gardena, CA 90248 • USA  
 TEL:(310) 532-1555 • (800) 421-1266 • FAX:(310) 324-3030  
 Web Site: www.marsair.com • E-mail:Info@marsair.com

PROJECT		OPTIONS/ITEMS	
TITLE			
COMMENTS		DATE 4/14/15	PAGE
		REV. NO	
MODEL NO. BD14 Series	DRAWING NO BD14E-F	DRAWN BY TVN	CHECKED BY
		FILE NAME	

# Electric Heated Drawing

## BD14 (Belt Driven 14) Series

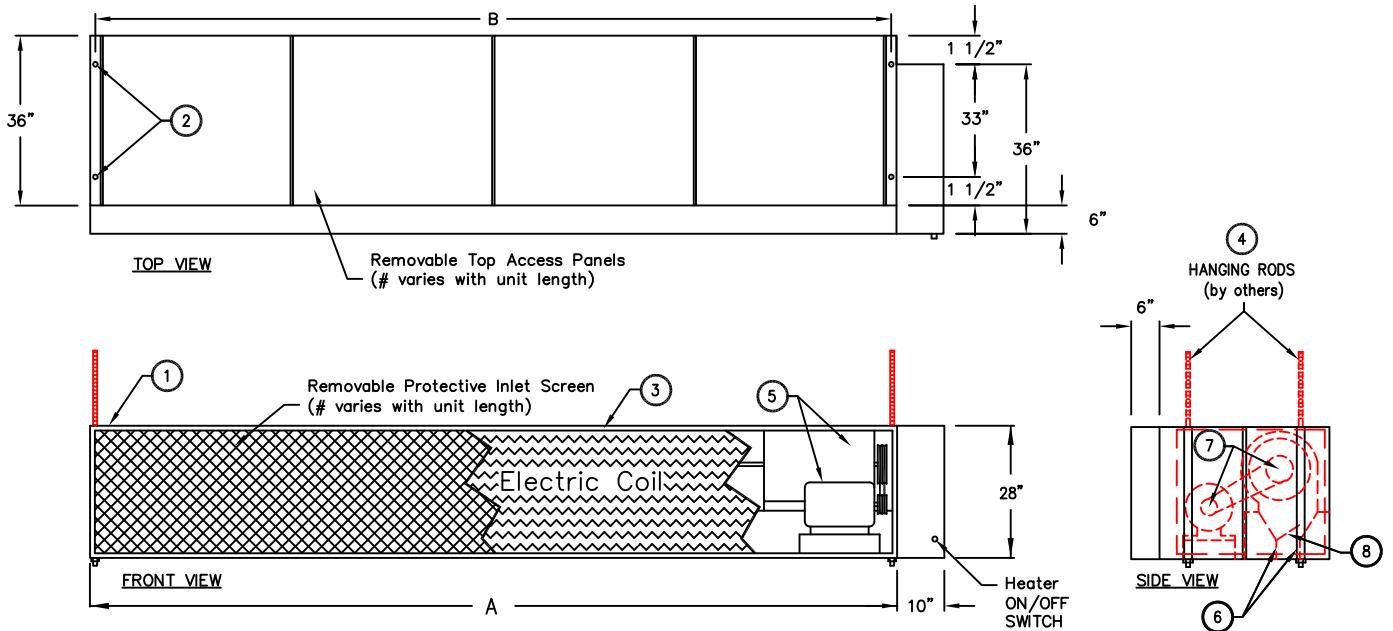

### 9 10 Recommended Accessories

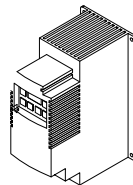

Variable Frequency Drive



Control Panels with Remote T'stat

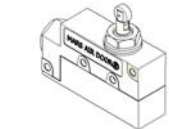

Door Limit Switches

\*- Use corresponding letters in "Electrical Data" columns to complete the model numbers.

MODEL NUMBER	NOZZLE LENGTH (in)	OVERALL LENGTH A (in)	MOUNTING WIDTH B (in)
BD1496-1E*-TS	96	107	105 1/2
BD14120-1E*-TS	120	131	129 1/2
BD14144-1E*-TS	144	155	153 1/2
BD14168-1E*-TS	168	179	177 1/2
BD14192-1E*-TS	192	203	201 1/2

### Notes:

- This product is designed to meet the National Electric Code (NEC) and is CSA Listed.
- (4) 5/8" mounting holes provided on for overhead mounting provided, (2) on each end.
- All units have a self contained one piece cabinet, fire retardant and corrosion proof paint lock metal double protected with baked on Titanium Silver color, rust preventative electrostatic polyurethane powder coating.
- Cabinet is to be mounted from overhead and has sufficient strength for suspension from both ends without intermediate support.
- Unit is to be installed such that air flow is unobstructed. Unit has a 4.5" air discharge nozzle containing adjustable air directional vanes with 40° sweep front to back. To prevent unit damage, the air curtain must be installed such that the bottom of the air curtain is not below the door header.
- Units are direct drive. One external top mounted 2"x4" J-box provided above each motor.
- Electric heater shown with heater component panel on right side, as standard. (Note: This is not the same as the optional remote air curtain unit control panel, see note 10.) Optional left hand mounting available. Special remote mounted heater component panel available for installations with space limitations. Contact factory for details and minimum installation space requirements.
- Wall mounted 24 volt thermostat with remote "heat/off/fan" switch is shipped loose and field installed. Terminal block provided inside control panel.
- Circuit protection as per NEC by others.
- Optional remote air curtain unit control panel and door limit switch are field installed and wired by others. The remote air curtain unit control panel is required when a door limit switch is used to automatically turn the air curtain on as door begins to open. Special remote mounted heater component panel (see note 7) is integrated with the optional remote air curtain unit control panel when the two options are selected.

# BD14 (Belt Drive) Series

Electric Heated

Model Lengths 96" – 192"



atmosphere is everything

14716 S. BROADWAY, GARDENA, CA 90248 • Ph: (310) 532-1555 Fax: (310) 532-3030 • [www.marsair.com](http://www.marsair.com)  
© Copyright Mars Air Systems, LLC 2014

## Electric Heated Data Sheet

**Applications: Environmental Separation: Max Height 16' / Insect Control: Max Height 14'**

BD14 (WindGuard)	Mechanical Data						Lab Data	
Model Number	Nozzle Length (in)	Length (in)	Depth (in)	Height (in)	Motor (hp)	Weight (lbs)	Max Velocity (fpm)	Max Volume (cfm)
BD1496-1E*-TS	96	107	42	28	5	750	4500	11700
BD14120-1E*-TS	120	131	42	28	5	875	4500	14650
BD14144-1E*-TS	144	155	42	28	7 1/2	1000	4500	17600
BD14168-1E*-TS	168	179	42	28	7 1/2	1125	4500	20500
BD14192-1E*-TS	192	203	42	28	10	1250	4500	23450

\* - Use corresponding letters in "Electrical Data" & "Heater Wattage Data" columns to complete the model numbers.

Note: Data above is for 60 Hz, 17% reduction in the performance data with 50 Hz.

### Features:

- ❖ Air Curtain
- ❖ 5 to 10 HP Heavy Duty TEFC Motors
- ❖ Air curtain has a self-contained cabinet with sufficient strength for fastening from overhead on both ends without intermediate support. Top and rear mounting holes provided (4) 3/4"
- ❖ Adjustable air directional nozzle with 40° sweep front to back
- ❖ Standard color is Titanium Silver
- ❖ Rust preventative electrostatic polyurethane powder coating
- ❖ All units are shipped fully assembled ready for installation
- ❖ 12-month parts warranty
- ❖ Freight Not Included (FOB Factory)
- ❖ Proudly Made in the USA

Electrical Data (FLA)	Heater Voltage (Voltage Code) Amperage		Heater Data	
	460v (H)	575v (I)	3Ø kW	Temp Rise (°F)
BD1496-1E*-TS	139	111	110	30
BD14120-1E*-TS	176	141	140	30
BD14144-1E*-TS	214	171	170	31
BD14168-1E*-TS	245	196	195	30
BD14192-1E*-TS	283	226	225	30

\* - Use corresponding letters in "Electrical Data" columns to complete the model numbers.

Note: For Ampacity Multiply FLA X 1.25

### Electric Heater Coil and Wiring

- ❖ Coils are an open type for rapid temperature rise to be located in the air curtain's intake directly in the air stream.
- ❖ Manual reset thermal overload protection provided
- ❖ Controls are externally mounted, prewired ready for power connection
- ❖ A heat ON/OFF switch is unit mounted on external controls

Model Number	Motor Amperage	
	460v/3Ø (H)	575v/3Ø (I)
BD1496-1E*-TS	6.5	5.3
BD14120-1E*-TS	6.5	5.3
BD14144-1E*-TS	10.0	8.9
BD14168-1E*-TS	10.0	8.9
BD14192-1E*-TS	13.0	10.3

\* - Use corresponding letters in "Electrical Data" columns to complete the model numbers.

Note: For Ampacity Multiply FLA X 1.25

### Mars Recommended Accessories (See Submittals for additional details):

- ❖ Door Limit Switches
    - 99-125, Industrial surface mounted magnetic switch (controller required)
  - ❖ Controllers
    - MCP\*-+E\*, Motor Control Panel, 120V control voltage (\* = HP Code [E for 5 HP, G for 7.5 HP, H for 10 HP], † = # of Motors, \* = Voltage Code)
      - MCP-TD, Adjustable time delay, 1sec-100hr (panel required)
      - MCP-24V, Low voltage control option (panel required)
      - BMS-306, BMS for monitor and control (panel required with MCP-24V)
- Note: Dry contact provided in panel for monitoring motor. 24Vac signal provided from panel for controlling motor

### Sound Levels: (measured at 10' in an open field)

5 HP Motor Unit = 73 dBA, 7 ½ HP Motor Unit = 74 dBA, 10 HP Motor Unit = 75 dBA

EXAMPLE

**BD14 96 - 1 E H - TS**

