

Vertical Mounted Air Curtain



atmosphere is everything

14716 S. BROADWAY, GARDENA, CA 90248 • Ph: (310)532-1555 Fax: (310)-532-3030 • www.marsair.com
© Copyright Mars Air Systems, LLC 2014

Vertical Mounted Kit for All Models

Vertical Mounting Kit Number	Description	Standard Color
09-500	Accessory, Kit, Vertical Mount, LPV2, All Heat Type, 2 Mtr Units Max	Obsidian Black
09-510	Accessory, Kit, Vertical Mount, STD2, All Heat Types, OB (Excl Elec Htd w/ 16kW/Mtr) (2 HW/S Max)	Obsidian Black
09-520	Accessory, Kit, Vertical Mount, HV2/EP2, All Heat Types, TS (Excl Gas) (2 HW/S Max)	Titanium Silver
09-530	Accessory, Kit, Vertical Mount, WM, Unhtd/HW/S, TS (2 units Max)	Titanium Silver
09-546	Accessory, Kit, Vertical Mount, BD, Unhtd Only, (Excl Gas) (25% of unit List) (2 units Max)	Titanium Silver
09-550	Accessory, Kit, Vertical Mount, BD & WM, Hot Water/Steam (25% of unit List) (2 units Max)	Titanium Silver

Features:

- ❖ This product is designed to be compatible with Mars Air Systems models. See table for model selection chart
- ❖ Standard color for LPV2/LPN2 and STD2/NH2 is Obsidian Black (OB) and for other series is Titanium Silver (TS)
- ❖ Up to 2 air curtain can be stacked on each other for taller entranceways. Center mounting brackets are factory installed for WM and BD series for easy installation.
- ❖ Vertical air curtains can be installed on both sides of wider entranceways for adequate protection
- ❖ Vertical stand-off pedestal is factory provided and shipped loose for right or left side field installation
- ❖ Safety steel mesh factory installed at nozzle to avoid accidental contact at discharge
- ❖ Modified intake screen with additional offset expanded metal factory installed to prevent accidental contact for WM and BD series
- ❖ Additional brackets for wheels and bearing locks factory installed for BD series
- ❖ Same end connection standard for Steam/Hot water heated models. Custom coil design offered for other configurations
- ❖ Remote mounted control panel is standard. Optional unit mounted control panel available
- ❖ Proudly Made in the USA

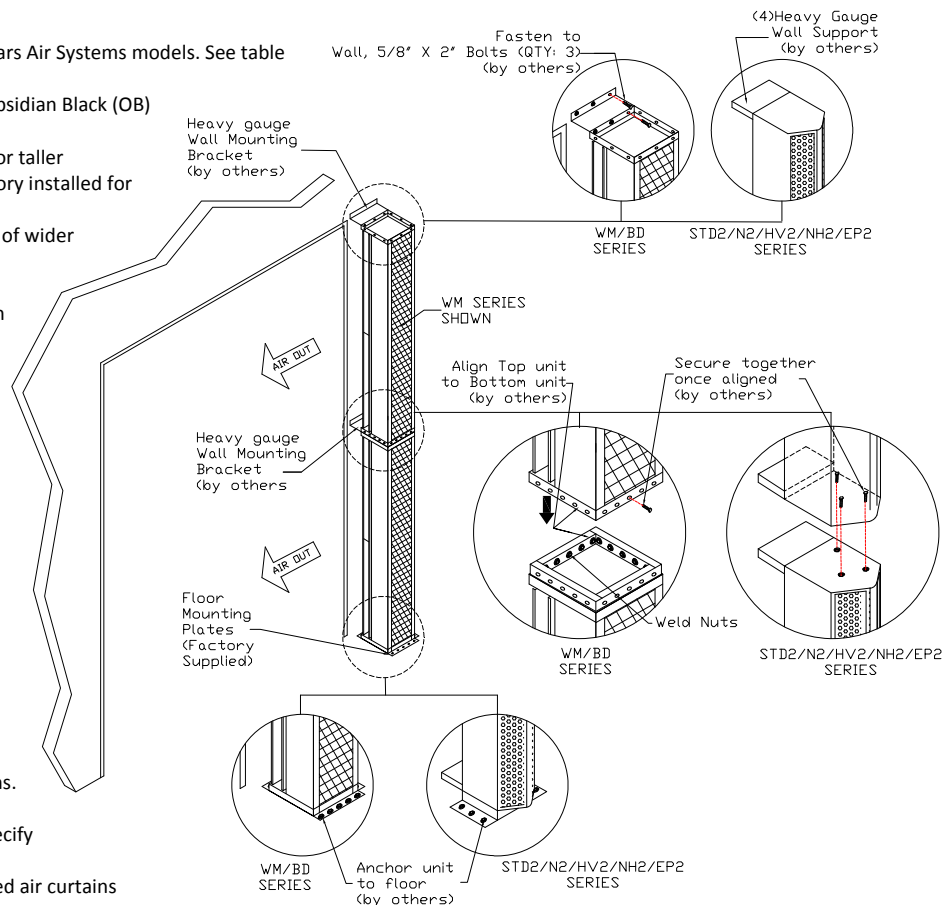

Options and Accessories:

- ❖ Custom colors available (Obsidian Black, Titanium Silver, Pearl White and Stainless Steel)
- ❖ Custom coil design offered for other configurations. Specify orientation, call factory.
- ❖ Unit mounted control panel options available. Specify orientation, call factory.
- ❖ Optional air diffusers available for vertical mounted air curtains
- ❖ For Electric Heated:
 - Not applicable for
 - STD2, 16kW / Motor for 208/230V, 3Ø
 - WMI/WMH, BD
 - Heat on Demand Mode Operation

NOTE: MARS AIR SYSTEMS, LLC reserves the right to change specifications and product design without notice. Such revisions do not entitle the buyer to corresponding changes, improvements, additions or replacements for previously purchased equipment.