

TOP VIEW

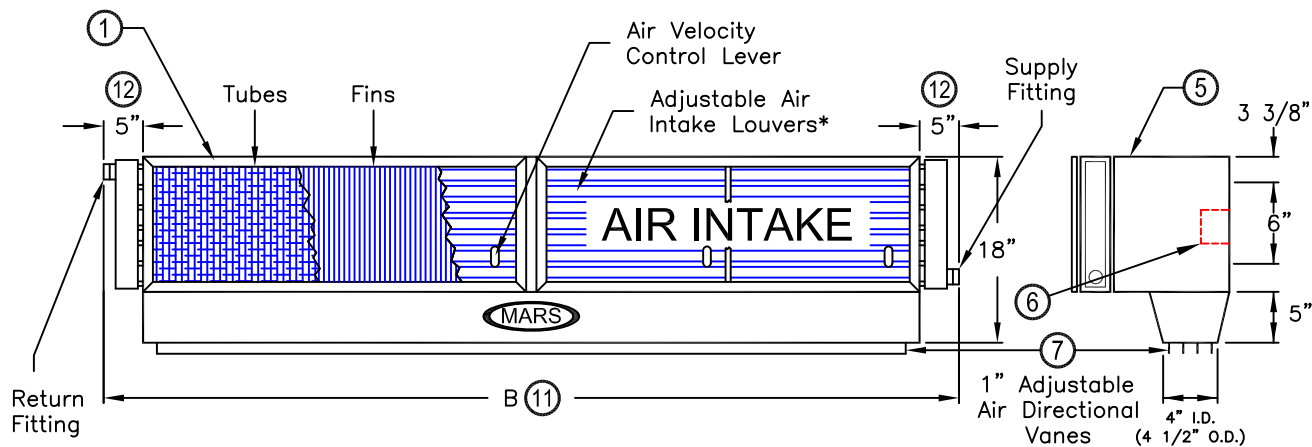

FRONT VIEW

SIDE VIEW

-2, -3 & -4 designates the number of motors.

NOTE: Louver assembly size and quantity varies with unit length.

MODEL NUMBER	NUMBER OF MOTORS	MOUNTING CENTERS A	OVERALL LENGTH B
HV48-1Y*	1	47 1/8"	58"
HV60-1Y*	1	59 1/8"	70"
HV72-2Y*	2	71 1/8"	82"
HV84-2Y*	2	83 1/8"	94"
HV96-2Y*	2	95 1/8"	106"
HV108-2Y*	2	107 1/8"	118"
HV108-3Y*	3	107 1/8"	118"
HV120-2Y*	2	119 1/8"	130"
HV120-3Y*	3	119 1/8"	130"
HV144-3Y*	3	143 1/8"	154"

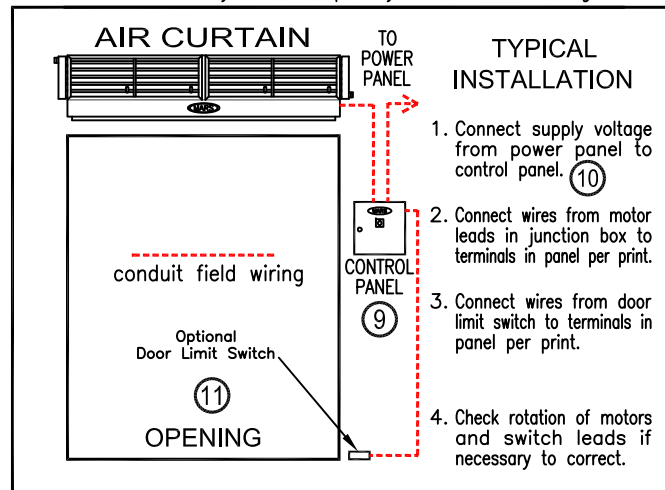

NOTES:

- This product is designed to comply with the National Electric Code (NEC), ETL listed for US & Canada, and bear the CE mark.
- All units have a self contained one piece cabinet, fire retardant and corrosion proof paint lock metal, double protected with baked on gray color, rust preventative electrostatic polyurethane powder coating.
- Coil casing is self contained one piece unpainted galvanized steel, bolted to air curtain housing. For coil casing finish to match air curtain housing, please specify. Coils are always shipped loose for field installation. Motor/Fan Assembly(s) 4 ft. and longer are shipped loose for field installation.
"C" dimension: Add 4 1/2" for one row and 6" for two row coil to unit depth.
- Cabinet has sufficient strength for fastening to wall on both ends without intermediate support.
- Internal J-Box(es) for electrical wiring.
- Unit is to be installed such that air flow is unobstructed. Air discharge nozzle containing adjustable air directional vanes with 40° sweep front to back.
- Optional motor control panel. Overloads are factory preset. Standard procedure is to ship panel loose for remote mount. Can be factory mounted on either left or right hand side of air curtain housing. Please specify.
- Circuit protection as per NEC by others.
- Optional door limit switch is field installed and is to be wired to the control panel. Switch to be mounted such that air curtain turns on as door begins to open.
- Hot Water application shown. For Steam, return fitting is on bottom of manifold and supply is on center of manifold. Coils with the same end supply and return fittings, subtract 5" from overall length.
- * When specifying one row design, use "Y" for steam and "W" for hot water. For two row design, use "X" for hot water and "Z" for steam. See Code chart on second page.



PROJECT	Model No.:
LOCATION	Drawing No.:
ARCHITECT	Date
ENGINEER	Sheet of
	Drawn By:
	Checked By:

MARS[®]
AIR SYSTEMS

14716 S. BROADWAY • GARDENA, CA 90248 • USA
TEL: (310) 532-1555 • (800) 421-1266 • FAX: (310) 324-3030
Web Site: www.marsair.com • E-mail: info@marsair.com

HIGH VELOCITY (HV) 1 HP STEAM AND HOT WATER HEATED MODELS

JOB:

**ARCHITECT/ENGINEER:
CONTRACTOR:**

DRWG.: _____
SHEET _____ **of** _____ **DATE:** _____

MARK	HIGH VELOCITY STEAM HOT WATER HEATED MODEL NUMBER ①	NO. REQ'D	LENGTH	WEIGHT (LBS) 1 ROW/2 ROW	MOTOR FAN DATA					HEATING CAPACITY OF COILS								dBA Measured 10 ft. from Nozzle	REMARKS
					MOTOR HP 1750** RPM	FLA* THREE PHASE		MAX FPM** @ NOZZLE	MAX CFM** @ NOZZLE	STEAM ②				HOT WATER ②					
						208/230V	460V			HEAT MBH		TEMP RISE °F		HEAT MBH		TEMP RISE °F			
										ONE ROW	TWO ROW	ONE ROW	TWO ROW	ONE ROW	TWO ROW	ONE ROW	TWO ROW		
	HV48-1*		4'	165/165		3.3/3.2	1.6	4000	4000	124	210	29	49	87	144	20	30	70	
	HV60-1*		5'	180/190	1	3.3/3.2	1.6	3200	4000	141	238	33	55	94	152	20	30	70	
	HV72-2*		6'	265/280	Two 1	6.6/6.4	3.2	5140	8000	210	362	24	42	164	272	20	30	73	
	HV84-2*		7'	280/300	Two 1	6.6/6.4	3.2	4570	8000	231	395	27	46	174	284	20	30	73	
	HV96-2*		8'	305/325	Two 1	6.6/6.4	3.2	4000	8000	250	426	29	49	177	283	20	30	73	
	HV108-2*		9'	320/345	Two 1	6.6/6.4	3.2	3600	8000	271	452	30	51	185	301	20	30	73	
	HV108-3*		9'	380/400	Three 1	9.9/9.6	4.8	5500	12000	318	545	24	42	224	360	20	30	75	
	HV120-2*		10'	360/385	Two 1	6.6/6.4	3.2	3200	8000	284	479	33	55	195	307	20	30	73	
	HV120-3*		10'	420/440	Three 1	9.9/9.6	4.8	4200	12000	338	579	26	45	255	410	20	30	75	
	HV144-3*		12'	460/500	Three 1	9.9/9.6	4.8	4000	12000	377	641	29	49	281	410	20	30	75	

NOTES: ① When specifying one row design use "Y" for steam and "W" for hot water, for two row design, use "X" for Hot Water and "Z" for steam. See code chart below
② MBH and air temperature rise based on 70° ambient air and (5 psi steam) or (200°F hot water).

EQUIPMENT SPECIFICATIONS - Standard Features

GENERAL: Air curtain shall be a Mars® Air Door brand air curtain: Type High Velocity Steam or Hot Water heated.

APPROVALS

Air curtains, excluding coils, shall be Underwriters Listed, Canadian Standards Association Certified and meet the requirements of the National Electric Code, (N.E.C.) ETL Listed for US & Canada, and bear the CE mark.

CABINET

Cabinets shall be self contained one piece housing with sufficient strength for fastening to wall on both ends without intermediate support. Cabinet constructed of fire retardant, corrosion proof paint lock metal and double protected with gray baked rust preventative electrostatic polyurethane powder coating. Cabinet to have mechanically adjustable variable air intake louver assembly capable of reducing outlet air velocity up to 60% with louvers in the totally closed position. Discharge air outlet nozzle shall be wedge shape containing adjustable air directional vanes with a 40° sweep front to back. Motor/fan assembly to be easily accessible for maintenance.

COIL CONSTRUCTION FOR BOTH HOT WATER & STEAM

Coils shall be constructed of .035" heavy tube wall x 5/8" OD seamless copper tubing with die formed aluminum fins. Tubes shall be arranged in a staggered pattern in the direction of air flow. Casings shall be not be less than 16 gauge galvanized steel with tube holes formed with extruded collars. Tubes shall mechanically expanded into fins to assure a uniform pressure bond throughout the entire length of each tube. Manifolds shall be of heavy seamless copper construction. All joints shall be brazed with high temperature silver brazing alloy. Fittings shall be of wrought copper or similar construction such that the entire fluid circuit shall be of compatible nonferrous materials. Manifold shall be fitted with 1/4" vent or drain fittings. Supply fitting is on the right side of coil. Return fitting is on the left side. Coils are shipped loose.

MOTORS AND BLOWER WHEELS

Motor(s) shall be totally enclosed air over (TEAO) type suitable for continuous heavy duty, all angle operation. Construction shall include sealed lifetime pre-lubricated ball bearings, resilient mounted and protected by an automatic reset thermal overload switch. Motor(s) to have quick disconnect plugs for fast easy removal of motor/fan assembly for inspection and cleaning. Motor(s) to have double extended shaft and direct drive, double inlet, dynamically balanced, forward curve squirrel cage blower wheels. Shipped loose for units over 4 feet long.

ELECTRICAL WIRING

All junction boxes are internally mounted one motor (1) - 2"x4"; two motors (1) 4"x4"; three or four motors (2) 4"x4".

GUARANTEE Shall be 18 months on all parts.

***-For Ampacity Multiply FLA X 1.25**

**** -17% Reduction in Performance on units with 50Hz.**

ACCESSORIES

Refer to the optional feature and accessories page.

EXAMPLE

① **HV 60 - 1 Z H - TS**

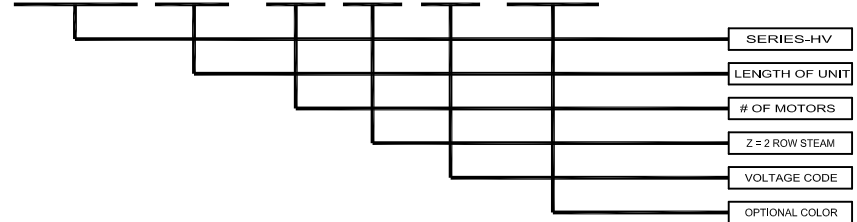

HEATING OPTION	CODE
1 ROW HOT WATER	W
2 ROW HOT WATER	X
1 ROW STEAM	Y
2 ROW STEAM	Z

SIZE	VOLTAGE	CODE
48"-144"	208/1/60	B
48"-144"	230/1/60	C
48"-144"	208/3/60	E
48"-144"	230/3/60	F
48"-144"	460/3/60	H
48"-144"	575/3/60	I

COLOR	CODE
OBSIDIAN BLACK	OB
TITANIUM SILVER	TS
PEARL WHITE	PW
SPARTAN BRONZE	SB
BATTLESHIP GRAY	BG

MADE WITH PRIDE IN THE USA

HIGH VELOCITY (HV) 1 HP STEAM / HOT WATER HEATED MODELS