

# INSTALLATION INSTRUCTIONS FOR WINDGUARD® BELT DRIVE INDUSTRIAL UNHEATED MODELS

## READ INSTRUCTIONS BEFORE UNCRATING

### SAVE THIS SHEET FOR FUTURE REFERENCE

#### PRELIMINARY

1. Carefully uncrate the unit.
2. Remove any optional items purchased that are shipped loose inside the unit. Set them aside for a later installation.
3. The motor may be serviced by removing the top access panel above the motor or by removing the front intake screen on the motor side.

**WARNING: TO REDUCE THE RISK OF FIRE, ELECTRIC SHOCK OR INJURY TO PERSONS, OBSERVE THE FOLLOWING:**

- A. Installation work or electrical wiring must be done by qualified person(s) in accordance with all applicable codes and standards, including fire-rated construction.
- B. The combustion airflow needed for safe operation of fuel burning equipment in the area may be affected by the unit's operation. Follow the heating equipment manufacturer's guideline and safety standards, such as those published by the National Fire Protection Association (NFPA), the American Society of Heating, Refrigeration and Air Conditioning Engineers (ASHRAE) and local code authorities.
- C. When cutting or drilling into a wall or ceiling, be careful not to damage electrical wiring and other hidden utilities.

FIGURE 1

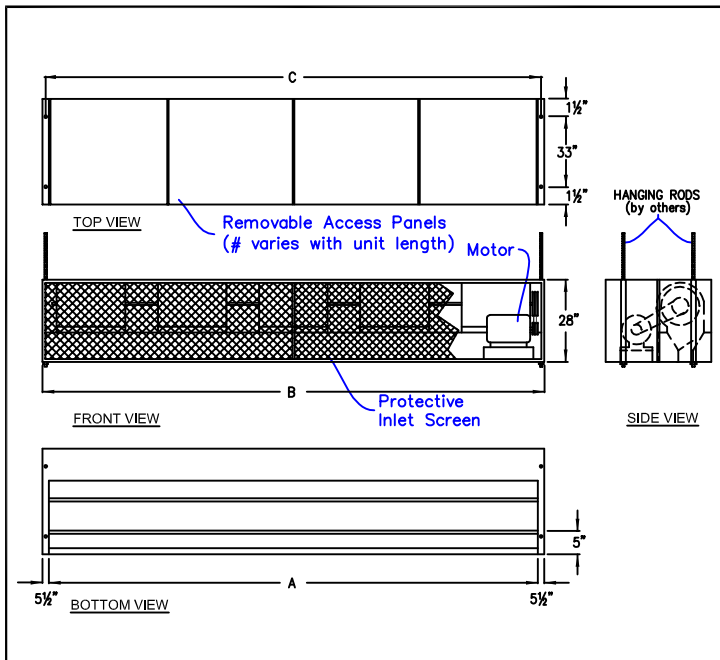
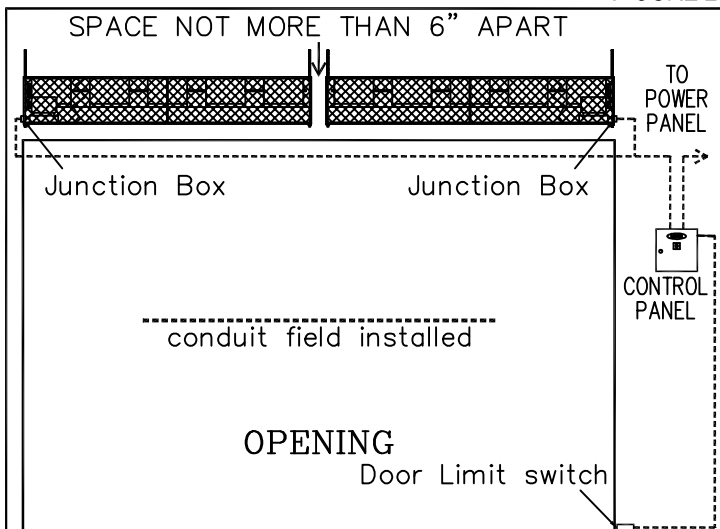

FIGURE 2



#### TO INSTALL THE AIR CURTAIN

1. Measure the housing, and then center it on the wall over the doorway opening.
2. The unit is equipped for overhead installation using (4) threaded rods and Heavy Duty Nuts and Washers. (By Others) The weights for each unit vary. Consult submittal sheets for weights. See Figures 1 & 3.
3. Mount the unit with the discharge nozzle 1" above the door opening. If the unit is mounted higher, move it 3/8" away from the wall for every 1" it is moved up above the door. Any void between wall and unit must be sealed for optimum performance. Rods may be used for overhead installation.
4. Use all four mounting holes when installing the housing.
5. When mounting multiple units side by side, allow no more than 6" between the units.
6. The motor, sheave and pulley are factory set and will need adjustment after two weeks of operation.
7. Connect motor to proper voltage. If the unit is three phase, check the rotation of the motor.

#### ADJUSTMENTS

1. Adjust the adjustable air discharge nozzle to proper position, with air flow slanted slightly outward around 10°.
2. Set air velocity control dampers so that the air stream just reaches the floor to prevent turbulent mixing of inside and outside air.
3. The unit is to be installed such that the airflow is unobstructed.

MODEL NUMBER	NOZZLE WIDTH A	OVERALL WIDTH B	MOUNTING WIDTH C
BD-**-096-UN	96"	107"	105 1/2"
BD-**-120-UN	120"	131"	129 1/2"
BD-**-144-UN	144"	155"	153 1/2"
BD-**-168-UN	168"	179"	177 1/2"
BD-**-192-UN	192"	203"	201 1/2"

\*\*—Models available for 14', 18', 22', 26', 30' high door openings. See submittal sheets for more information

#### OPTIONAL CONTROL PANEL INSTALLATION

- A. Connect supply voltage from power panel to control panel. Circuit protection as per NEC by others.
- B. Connect motor leads in junction box to terminals in control panel per print. Motor control panel overloads are factory preset.
- C. Connect wires from door limit switch to terminals in control panel per print.
- D. Re-check rotation of blower wheels. Switch leads if necessary to correct. (three phase only)
- E. The door limit switch has normally closed contacts. The contacts open when the door shuts depressing the plunger turning the blowers off.

FIGURE 3

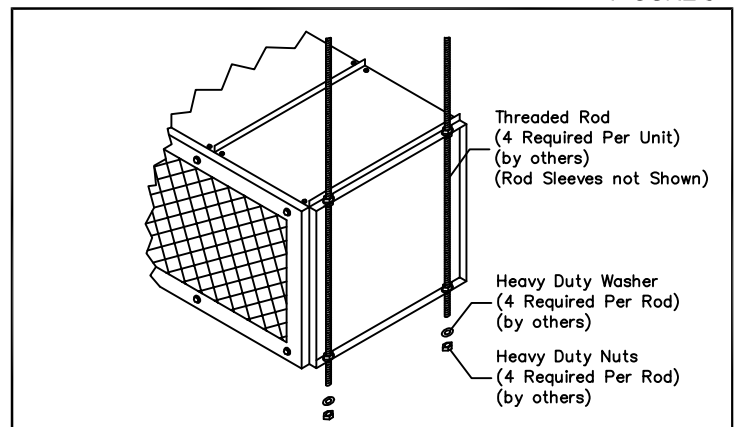

# MAINTENANCE INSTRUCTION

**WARNING: TO REDUCE THE RISK OF FIRE, ELECTRIC SHOCK OR INJURY TO PERSONS, OBSERVE THE FOLLOWING:**

- A. Use this unit only in the manner intended by the manufacturer. If you have questions, contact the manufacturer.
- B. Before servicing or cleaning the unit, switch power off at service panel and lock service panel to prevent power from being switched "ON" accidentally.
- C. To reduce the risk of electric shock, DO NOT use this fan with any solid state speed control device.

## PRELIMINARY

It is imperative to keep the fans clean. Failure to do so may cause excess buildup of residue. This will lower efficiency and eventually throw fans out of balance, which can shorten the life of the blower wheels and cause undue wear on the bearings. The time between cleaning depends upon the type and amount of particles floating

in the air. Under normal circumstances, the system will only require cleaning approximately once a year.

Clean motors and fans when necessary for peak operational efficiency. Motor and fans may be easily cleaned by removing the access panels above the unit. Check the belt tension after the first 2-3 weeks of operation, as belts loosen with the initial use. The belts should be periodically checked for wear and be replaced as needed. The usage time will determine belt life. Contact factory for details.

Occasionally remove the screens and wash with soap and water. At the same time, it is advisable to wipe any accumulation of dirt off the motor.

**Motor requires no lubrication as all motors have lifetime prelubricated, double sealed ball bearings. However, the (2) pillow block bearings on the drive side of the unit requires lubrication 2-3 times annually, depending on usage.**

## ALL PARTS ARE FOB OUR FACTORY - GARDENA, CA

When ordering parts, include the serial and model number from the name plate of the unit. When ordering blower wheels, specify whether steel or stainless steel.

## MOTOR CHARACTERISTICS AVAILABLE (Three Phase Only)

5 HP - 30 HP.....1750 RPM

## INTAKE SCREENS · SERVICE ACCESS PANELS · DIRECTIONAL NOZZLES

### CONTROL CABLES

Specify model number when ordering

## BLOWER WHEEL AND HOUSING

10" Blower Wheel and Housing sold complete. 1' Bore.

## DRIVE ASSEMBLY

Complete drive assembly consists of a sheave, pulley and belts. Specify the sizes when ordering.

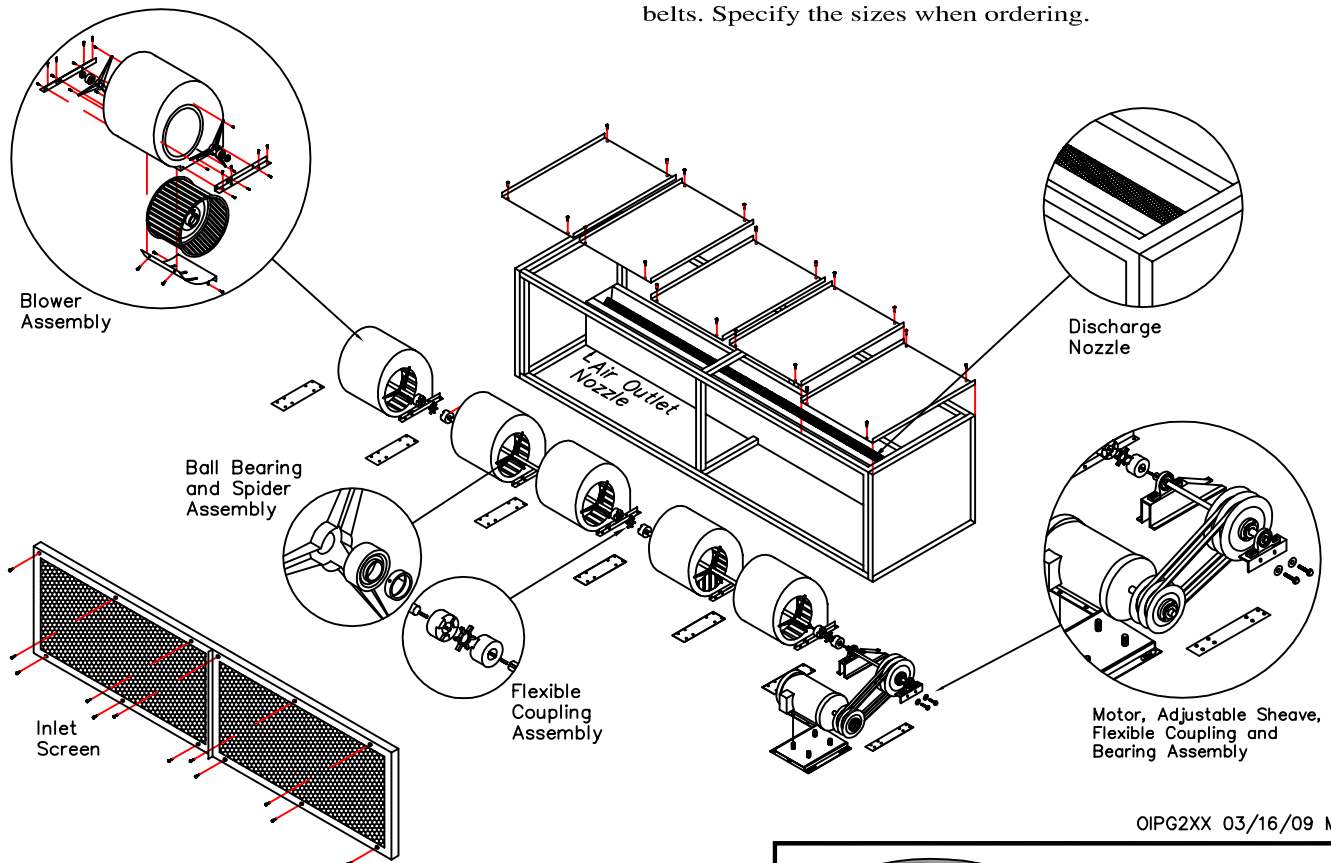

OIPG2XX 03/16/09 MB



AIR SYSTEMS

*Air Doors*  
BRAND AIR CURTAIN

14716 S. BROADWAY • GARDENA, CA 90248  
Tel: (310) 532-1555 • (800) 421-1266 • Fax: (310) 324-3030  
Web Site: [www.marsair.com](http://www.marsair.com) • E-mail: [info@marsair.com](mailto:info@marsair.com)

**THE BEST AIR CURTAINS ON EARTH COME FROM MARS®**