

INSTALLATION INSTRUCTIONS FOR UNHEATED STANDARD, HIGH VELOCITY, EXTRA POWER AND INDUSTRIAL NSF MODELS

READ INSTRUCTIONS BEFORE REMOVING FROM CARTON

SAVE THIS SHEET FOR FUTURE REFERENCE

PRELIMINARY

1. Before removing the unit from the carton, unscrew the plastic nuts and remove the adjustable velocity control louver(s). Industrial NSF models have Aluminum Mesh Intake Filter instead of louvers.
2. Remove the Motor/Fan Assembly (MFA) from its carton. Industrial models 4 ft. and longer have the MFA shipped separately. If the MFA is inside the unit, loosen the cord from the watertight fitting and pull the cord out (3Ø) or pull the plug from the motor (1Ø), then remove the two wing nuts on each side of the pan.
3. Remove the housing from the carton.

WARNING: TO REDUCE THE RISK OF FIRE, ELECTRIC SHOCK OR INJURY TO PERSONS, OBSERVE THE FOLLOWING:

- A. Installation work or electrical wiring must be done by qualified person(s) in accordance with all applicable codes and standards, including fire-rated construction.
- B. The combustion airflow needed for safe operation of fuel burning equipment in the area may be affected by the unit's operation. Follow the heating equipment manufacturer's guideline and safety standards, such as those published by the National Fire Protection Association (NFPA), the American Society of Heating, Refrigeration and Air Conditioning Engineers (ASHRAE) and local code authorities.
- C. When cutting or drilling into a wall or ceiling, be careful not to damage electrical wiring and other hidden utilities.

FIGURE 1

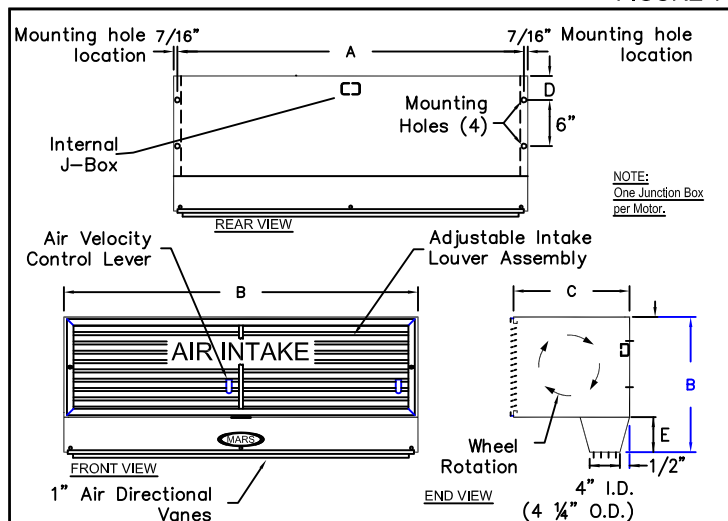
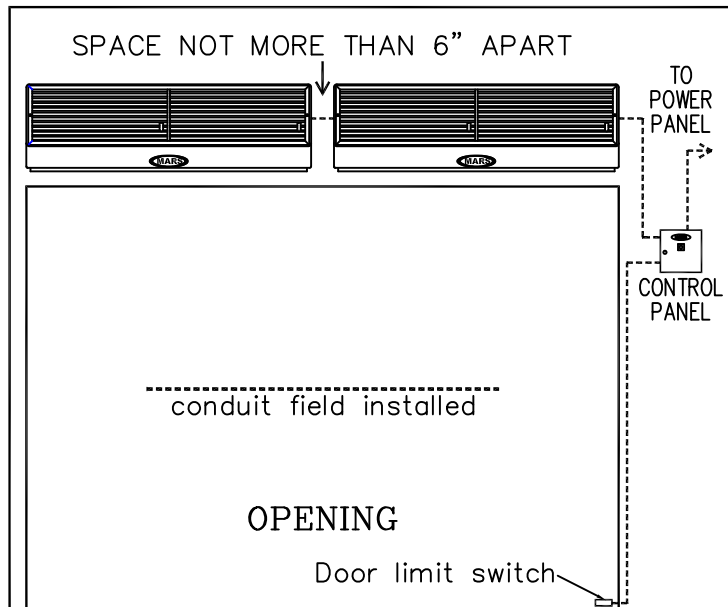

FIGURE 2



TO INSTALL HOUSING AND MOTOR/FAN ASSEMBLY

1. Measure the housing, and then center it on the wall over the doorway opening.
2. Spot holes through 7/16" mounting holes. (2) on each end of the housing. If necessary, drill extra holes in the back of the housing to align with stud spacing. (see Figure 1)
3. Mount the unit with the discharge nozzle 1" above the door opening. If the unit is mounted higher, move it 3/8" away from the wall for every 1" it is moved up above the door. Any void between wall and unit must be sealed for optimum performance. Threaded rods may be used for overhead installation.
4. Use all four mounting holes when installing the housing.
5. When mounting multiple units side by side, allow no more than 6" between the units. (see Figure 2)
6. Replace Motor/Fan Assembly(s) in the housing and secure with wingnuts. Re-connect all motor connections.
7. Replace the intake louver or inlet screen and fasten with the hex nuts.
8. Connect motor to proper voltage. If the unit is three phase, check the rotation of the motor. (see Figure 1)

ADJUSTMENTS

1. Pull air directional vanes in air discharge nozzle to proper position with air flow slanted slightly outward around 15°.
2. Set air velocity control louvers so that the air stream just reaches the floor to prevent turbulent mixing of inside and outside air.
3. The unit is to be installed such that the airflow is unobstructed.

NOTE: MODEL NUMBER DESIGNATES THE LENGTH OF THE UNIT IN INCHES, WHICH IS DENOTED AS "L". ALL DIMENSIONS ARE IN INCHES.

MODEL LENGTH	HP	MOUNTING CENTER A	HEIGHT B	DEPTH C	MOUNTING HOLE LOC. D	NOZZLE HEIGHT E
36*	1/2	35 1/8	14	11 1/4	3	3 1/4
38*	1/2	37 1/8	14	11 1/4	3	3 1/4
42*	1/2	41 1/8	14	11 1/4	3	3 1/4
48*	1/2	47 1/8	14	11 1/4	3	3 1/4
64	2 @ 1/2	63 1/8	14	11 1/4	3	3 1/4
72*	2 @ 1/2	71 1/8	14	11 1/4	3	3 1/4
78	2 @ 1/2	77 1/8	14	11 1/4	3	3 1/4
84	2 @ 1/2	83 1/8	14	11 1/4	3	3 1/4
96	2 @ 1/2	95 1/8	14	11 1/4	3	3 1/4
96	3 @ 1/2	95 1/8	14	11 1/4	3	3 1/4
108	2 @ 1/2	107 1/8	14	11 1/4	3	3 1/4
108	3 @ 1/2	107 1/8	14	11 1/4	3	3 1/4
120	3 @ 1/2	119 1/8	14	11 1/4	3	3 1/4
144	3 @ 1/2	143 1/8	14	11 1/4	3	3 1/4
144	4 @ 1/2	143 1/8	14	11 1/4	3	3 1/4
42*	1	42 1/8	18	14	3 3/8	5
48*	1**	47 1/8	18	14	3 3/8	5
60	1**	59 1/8	18	14	3 3/8	5
72	2 @ 1**	71 1/8	18	14	3 3/8	5
84	2 @ 1**	83 1/8	18	14	3 3/8	5
96	2 @ 1**	95 1/8	18	14	3 3/8	5
96	3 @ 1	95 1/8	18	14	3 3/8	5
108	2 @ 1**	107 1/8	18	14	3 3/8	5
108	3 @ 1**	107 1/8	18	14	3 3/8	5
120	2 @ 1**	119 1/8	18	14	3 3/8	5
120	3 @ 1**	119 1/8	18	14	3 3/8	5
144	3 @ 1**	143 1/8	18	14	3 3/8	5
144	4 @ 1	143 1/8	18	14	3 3/8	5

* - Designates Lengths of NSF Models with corresponding Horse Power.

** - Also available with 3 Horse Power Motors for the EP Models.

OPTIONAL CONTROL PANEL INSTALLATION

- A. Connect supply voltage from power panel to control panel. Circuit protection as per NEC by others.
- B. Connect motor leads in junction box(es) to terminals in control panel per print. Motor control panel overloads are factory preset.
- C. Connect wires from door limit switch to terminals in control panel per print.
- D. Check rotation of blower wheels. Switch leads if necessary to correct. (three phase only)
- E. The door limit switch has normally closed contacts. The contacts open when the door shuts depressing the plunger turning the Air Curtain off.

lance, which can shorten the life of the blower wheels and cause undue wear on the bearings. The time between cleaning depends upon the type and amount of particles floating

cleaning approximately once a year.
Clean motors and fans when necessary for peak operational efficiency. Motor-fan assembly may be easily cleaned by removing it from the housing. Remove the Motor/Fan Assembly from the housing by loosening the watertight fitting and pulling the cord out (3 phase) or by pulling the plug from the motor (1 phase), then removing the two wing nuts on either side of the pan.

Occasionally remove the velocity control louvers and/or inlet screens and wash with soap and water. At the same time, it is advisable to wipe any accumulation of dirt off the motor.

No lubrication is necessary as all motors have lifetime prelubricated, double sealed ball bearings. Motor contains automatic thermal overload protection as standard.

ALL PARTS ARE FOB OUR FACTORY - GARDENA, CA
1/2, 1 or 3 in part numbers below designates motor horse power in air curtain. When ordering parts, include the serial and model number from the name plate of the unit. When ordering blower wheels, specify whether steel or stainless steel.

MOTOR CHARACTERISTICS AVAILABLE (All Voltage and Phase)
1/2 HP.....1750 RPM 1 HP.....1750 RPM
3 HP.....3400 RPM

MOTOR/FAN ASSEMBLY
Complete assembly consists of a motor, blower wheel, blower housing and motor pan. Available in any horse power, voltage and phase.

MOTOR PAN
MP-30-1/2 · MP-30-1 · MP-30-3

VELOCITY CONTROL LOUVERS · INTAKE FILTERS · DIRECTIONAL VANES
AIR CURTAIN HOUSING
Specify model number when ordering

BLOWER HOUSING
Universal housings are good for either side of the motor. All sizes available in Polymars® and metal.

BLOWER WHEEL

MOTOR HP	METAL BLOWER WHEEL

NOTE: Universal indicates the wheel may be used on either side of the motor. Direction of wheel rotation is not required.

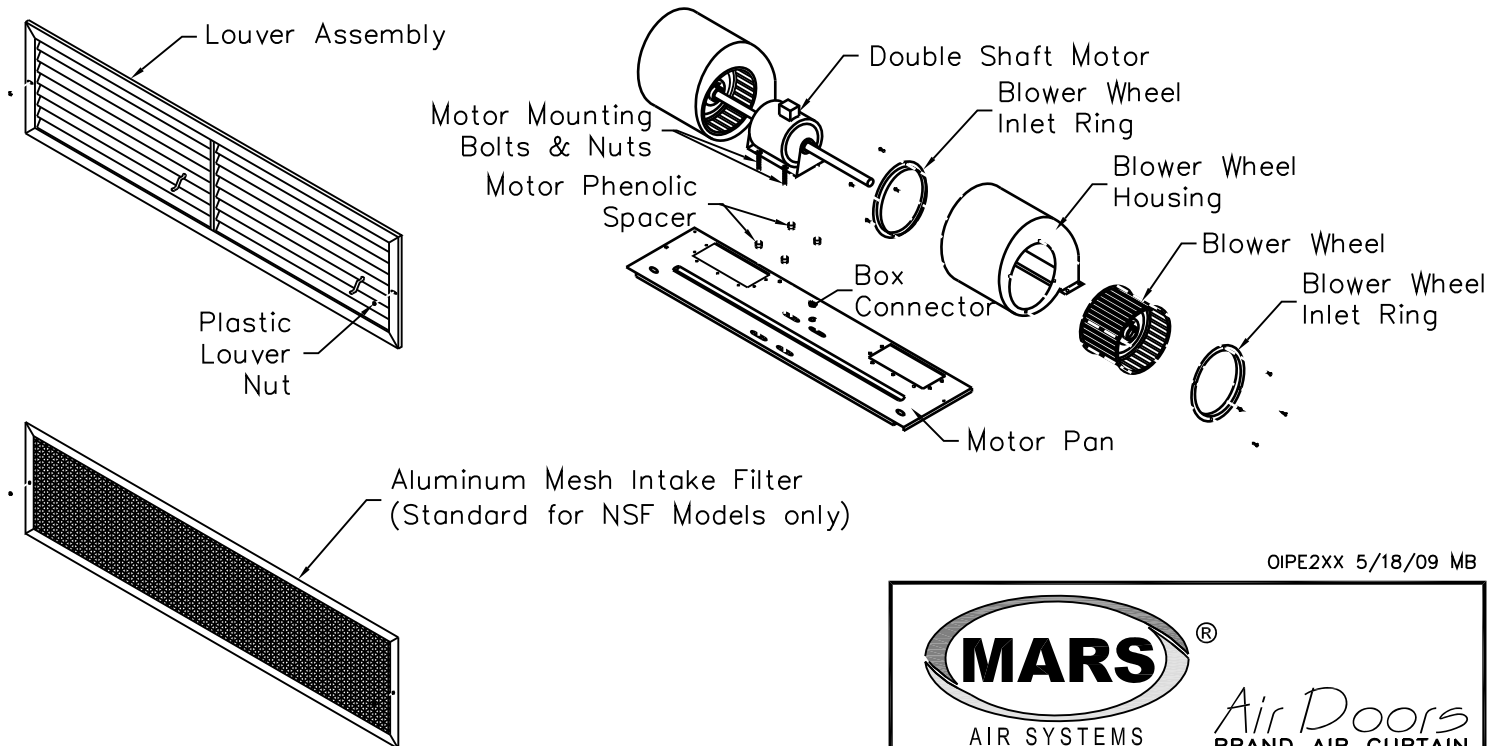

OIPE2XX 5/18/09 MB



MARS[®]
AIR SYSTEMS

Air Doors
BRAND AIR CURTAIN

14716 S. BROADWAY · GARDENA, CA 90248
Tel: (310) 532-1555 • (800) 421-1266 • Fax: (310) 324-3030
Web Site: www.marsair.com E-mail: info@marsair.com

THE BEST AIR CURTAINS ON EARTH COME FROM MARS®