

## LOW PROFILE (LPV) VARIABLE SPEED AND LOW PROFILE (LPN) NSF COMMERCIAL SERIES

### Installation, Operation and Maintenance Manual

Please read and save these instructions. Read carefully before attempting to assemble, install, operate or maintain the product described. Protect yourself and others by observing all safety information. Failure to comply with these instructions could result in personal injury and/or property damage. Retain these instructions for future reference.

#### OVERVIEW

Mars Air Curtains are designed to cover door openings, providing both temperature control/environmental separation and flying insect control, when the building's doors are opened. Typical installation heights are: LoPro Series; LPV

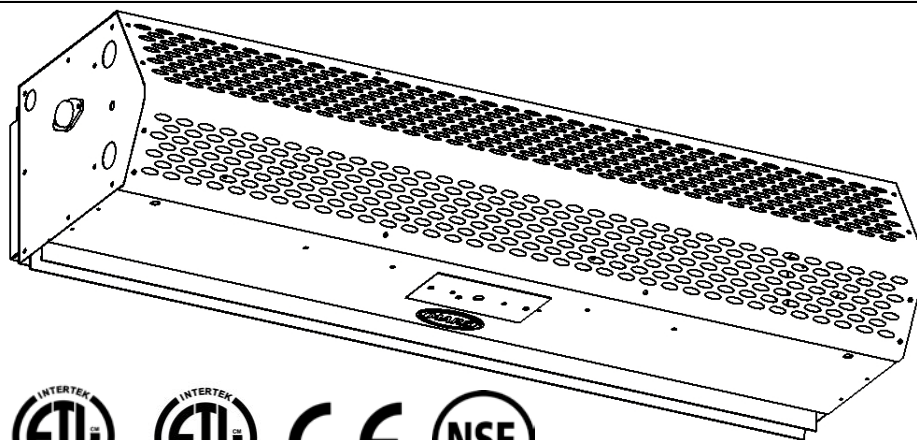

(Variable Speed) models (Environmental up to 8'), LPN (NSF for Customer Entrances) models (Flying Insect Control up to 7') and LPN-F (NSF for Counter Top/Pass Through Windows) models (Flying Insect Control up to 4' from Counter Top) All NSF Certified Models (ETL) should be mounted at the Flying Insect Control heights referenced above. The units are typically wall mounted horizontally above the door opening. They can also be suspended from the ceiling. The units are ETL Listed, Canada and US, for either an inside or outside mount and ETL Sanitation Certified. Heated units must be mounted on the inside or the protected side of the opening. The motors used in all LoPro Series are 1/6HP.

The LoPro Series come standard with a stamped air intake screen(s). The LPV models can be configured with an aluminum mesh filter(s) as an option. The LPN models 25", 28" and 30" and all LPN-F models come standard with an aluminum mesh air intake filter(s) in conjunction with the punched air intake screen(s).

#### GENERAL SAFETY INFORMATION

Use this product only in the manner intended by the manufacturer. If you have any questions, contact the manufacturer. Only qualified personnel should install

this product. Installing personnel should have a clear understanding of these instructions and should be aware of general safety precautions. Improper installation can result in electric shock, possible injury due to

coming in contact with moving parts, as well as other potential hazards.



#### WARNING

- To reduce the risk of fire, electric shock or injury to persons, observe the following.
- Always disconnect, lock and tag power source before installing or servicing product.
  - Installation work or electrical wiring must be done by qualified person(s) in accordance with all applicable codes and standards, including fire-rated construction.
  - The combustion airflow needed for safe operation of fuel burning equipment in the area may be affected by the product's operation. Follow the heating equipment manufacturer's guideline and safety standards, such as those published by the National Fire Protection Agency (NFPA), the American Society of Heating, Refrigeration and Air Conditioning Engineers (ASHRAE) and local code authorities.
  - When cutting or drilling into a wall or ceiling, be careful not to damage electrical wiring and other hidden utilities.



#### WARNING

Precaution should be taken in explosive atmospheres.



## WARNING

When servicing the product, motor may be hot enough to cause pain or injury. Allow motor to cool before servicing.

## RECEIVING AND INSPECTION

Upon receiving the product, check to make sure all items are accounted for by referencing the Bill of Lading to ensure all items were received. Inspect each carton for shipping damage before accepting delivery. Notify the freight carrier if any damage is noticed. The carrier will make notification on the delivery receipt acknowledging any damage to the product. All damage should be noted on all copies of the Bill of Lading which is countersigned by the delivering carrier. A Carrier Inspection Report should be filled out by the carrier upon arrival and a report given to the Traffic Department. If damaged upon arrival, file a claim immediately with the carrier. Any physical damage to the unit after acceptance is not the responsibility of Mars Air Systems.

## UNPACKING

Verify that all parts, components and accessories, and the correct quantities of each have been received. If any items are missing, report shortages to Mars Air Systems directly to arrange for obtaining the missing items. Again, verify quantities received against those on the Bill of Lading only, as multiple shipments may be involved.

## INSTALLATION

### Typical Mounting – Wall or Ceiling Mounted Horizontally Above the Door Opening

1. Remove the air intake grille(s) and/or air intake filter(s) from the product and set aside. Gently remove all packaging materials, hardware and all other accessories from interior of unit prior to operating. Severe unit damage will occur if these items are not removed prior to operation.
2. Lay unit on its top with directional vanes pointing up and remove the Tek Screws from the wall mounting plate, just behind the discharge nozzle, and remove the mounting plate from the unit. (FIG. 1) Measure the mounting plate and center it over the opening. The air curtain shall be equal to or greater than the width of the opening.
3. Install the mounting plate(s) above the opening. Multiple pre-punched 7/16" mounting holes are provided for your convenience. These holes must be utilized to secure the product to the wall. All hardware is field provided by others.
4. Align the tabs on the rear of the unit with the slots provided on the wall mounting plate (FIG. 2). The

bottom flange on the unit must also drop in the bottom channel of the wall mounting plate. Replace the Tek Screws to secure the unit in place.

**Note:** If the holes provided on the bottom of the unit and the bottom of the wall mounting plate do not align, remove the unit and re-install. The holes on the bottom channel of the wall mounted plate must be on the bottom.

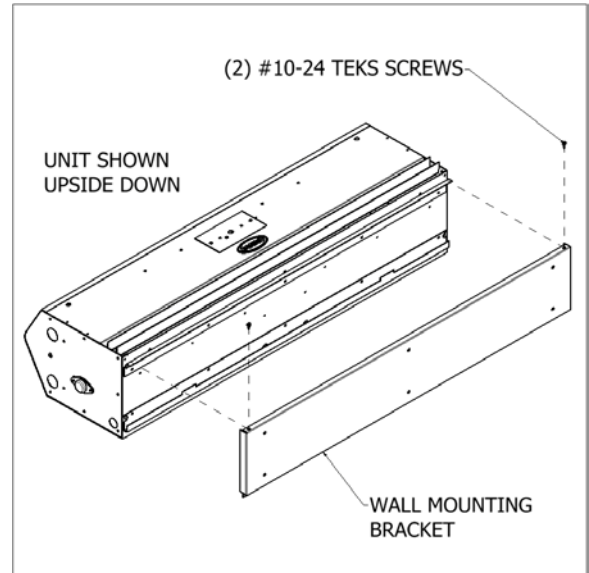

FIG. 1

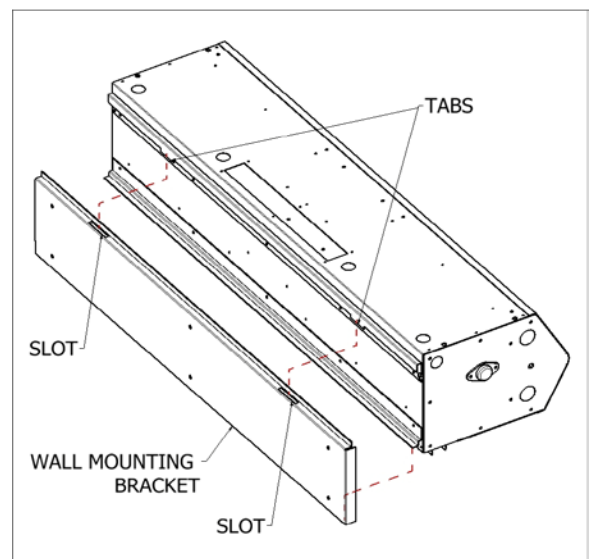

FIG. 2

5. Mount the product such that the discharge is 1" above the opening and all obstacles. (FIG. 3)

**Note:** If the product is installed higher than the recommended 1" above the opening, then it must be moved 3/8" away from the wall for every 1" that it is moved up. Any void between the wall and the product must be sealed, by others, to optimize performance.

6. Use four (4) threaded rods for overhead installation or four (4) threaded bolts for wall installation. All hardware is field provided by others. (FIG. 3)

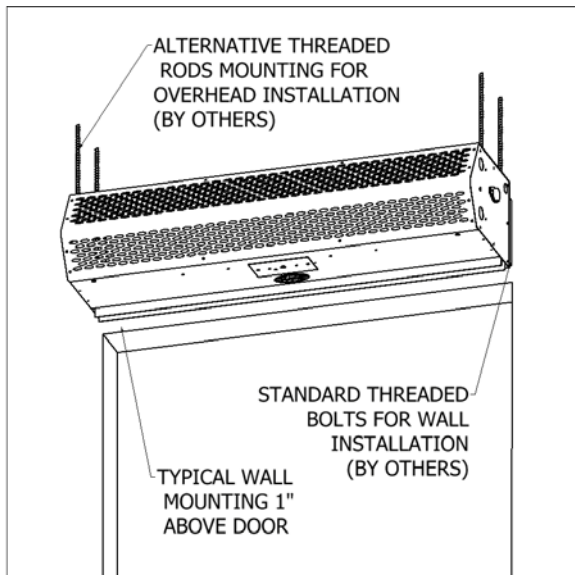

FIG. 3

7. If applicable, optional Adjustable Mounting Brackets, Side Extension Plates and Extended Wall Mounted Brackets are also available for installations over a Vertical Lift or Drum Roll-up type door. (Reference **Accessory Installation Supplement**)
8. If applicable, for tandem installation or products mounted side by side, allow no more than 6" between the two products. For overhead installation using threaded rods, the products may require a beam, by others, to span the full distance of the mounting length. (Reference **Accessory Installation Supplement**)
9. All wires must be connected internal of the unit and some knockouts are provided. However, it may be necessary to create your own knockout, as required.
10. The unit must be wired per NEC and local codes.

### Electrical Field Wiring

The unit and any optional accessories must be wired with the proper voltage to the junction box per the wiring diagram. (FIG. 4, unheated products only)

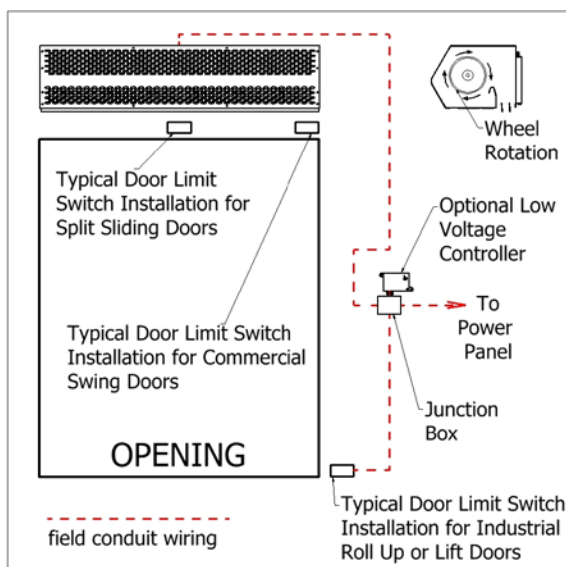

FIG. 4

### NOTE

For accessory installation, reference **Accessory Installation Supplement**.

For heated products, reference **Heated Products Supplement**.

### START-UP

This product has been assembled and tested at the factory prior to shipping. The following procedures should be performed to assure its performance. Before continuing with the start-up, it is important to recognize the safety controls furnished with the unit.



### WARNING

Prevent hazard of electrical shock. More than one disconnect switch may be required to de-energize this product.



### WARNING

The following items must all be completed by a qualified installer and checked off when completed

- A. Re-check that the product has been installed properly and is level and secure.
- B. Check all terminal screws are tight and field wiring is connected in accordance to National Electrical Code and wired per the enclosed wiring diagram. For electric heated models, ensure that the coils are secured and not touching each other on any metal surface.
- C. Verify proper voltage prior to powering the product. (See product label for reference).
- D. Check all field wired components "if supplied" are wired correctly.
- E. Check that the inlet air supply and the discharge air supply are free of obstructions.
- F. Check that all air filter(s) and/or air intake grille(s) are in place and installed properly, as originally shipped.
- G. Verify voltage to the product once more and turn power on.
- H. Regardless of whether the product is mounted on the inside or outside of the door opening, set the air directional vanes in the discharge nozzle slightly outward to approximately 10-15° towards the outside, or the wind load. (FIG. 5).

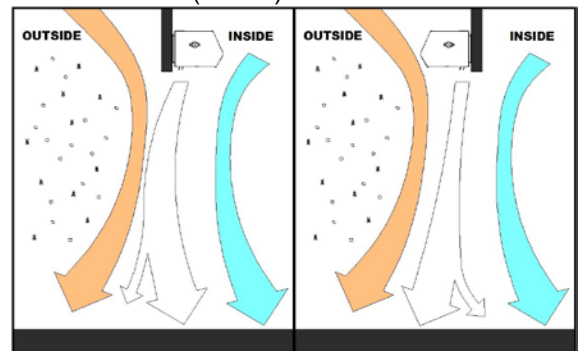



FIG. 5

- I. For products with control panels, turn the HOA (Hand-On-Auto) selector switch to “On” position and open the door to energize the product. For products without a control panel or an On/Off switch, open the door to energize the product.
- J. If heated products are installed, reference **Heated Products Supplement**.
- K. For three phase units, verify direction of rotation of blower wheels (note direction arrows on the blower wheel housing). Correct if needed by changing polarity of three phase power.
- L. **VERY IMPORTANT** Using a clamp meter, measure the amperage to each motor and ensure that they do not exceed the amperage listed on the product label.
- M. If applicable, adjust the air intake grille(s) such that the output air stream reaches the floor. For temperature control and environmental separation applications, the air stream should reach the floor with sufficient strength to create an air seal around the door opening without creating turbulent mixing of the inside and outside air. For flying insect control applications, the air stream should reach the floor with maximum strength. If after proper installation and adjustment, the product appears to be producing too little or too much air for the application, contact the manufacturer.

- 2. Use a damp cloth and either a warm mild soapy water solution or bio-degradable degreaser, to wipe down the exterior components of the housing.
- 3. To access the interior of the product, remove the air intake grille(s) and/or air intake filter(s). This is accomplished by removing the screws on the face of the air intake grille(s)/filter(s).
- 4. Thoroughly clean the air intake grille(s)/filter(s).
- 5. Thoroughly wipe down the motor, blower wheels and blower wheel housings. Be careful not to spray the motor with a water hose.
- 6. The motor(s) require no additional lubrication. They are permanently lubricated and feature double sealed ball bearings.
- 7. To re-install the product, reverse the procedures above.
- 8. Reconnect the power source to the product.
- 9. If you have any questions regarding the maintenance of the product, contact the manufacturer.

## MAINTENANCE

	<b>WARNING</b>
<p>To reduce the risk of fire, electrical shock or injury to persons, observe the following:</p> <ul style="list-style-type: none"> <li>A. Maintenance is to be performed only by qualified personnel who are familiar with local codes and regulations and are experienced with this type of product.</li> <li>B. Before servicing or cleaning the product switch power off at service panel and lock service panel to prevent power from being switched “ON” accidentally.</li> </ul>	

Routine maintenance is required to keep this product operating at its peak performance and efficiency. Over time, the housing, air intake grille, air intake filter, blower wheels and motor(s) will accumulate a build up of dust, debris and other residue. It is imperative to keep these components clean. Failure to do so will not only lower operational efficiency and performance, but also reduce the useful life of the product. The time between cleanings depends on the application, location and daily hours of use. On average, under normal use conditions, the product should require a thorough cleaning once every six (6) months.

### To clean the product, perform the following:

- 1. Verify the product has been disconnected from the power source.

## TROUBLESHOOTING

PROBLEM	CAUSE	SOLUTION
NO AIR BLOWING OUT OF DISCHARGE NOZZLE	<ul style="list-style-type: none"> <li>- No power being supplied to the unit from the electrical power source</li> <li>- Circuit breaker is tripped</li> <li>- Blown fuses on power supply</li> <li>- Motor overload is open or tripped</li> <li>- Motor contactor / relay defective (if applicable)</li> <li>- Failed switch</li> </ul>	<ul style="list-style-type: none"> <li>- Confirm power source / check if in on position</li> <li>- Reset circuit breaker</li> <li>- Replace fuses</li> <li>- Allow the motor to cool down; motor has auto reset internal overload; if unit is panel equipped, press reset button on overload inside panel, or replace motor overload if overload remains tripped</li> <li>- Check voltage to coil; check contacts to see if they are pulling in</li> <li>- Replace or repair limit switch</li> </ul>
MOTOR IS RUNNING BUT FANS ARE NOT SPINNING	<ul style="list-style-type: none"> <li>- Loose or broken coupling (belt drive)</li> <li>- Loose set screws on wheel hubs</li> <li>- Fan spinning inside fan housing</li> <li>- Broken fan hub</li> </ul>	<ul style="list-style-type: none"> <li>- Replace or tighten coupling</li> <li>- Tighten set screws on motor shaft flats</li> <li>- Tighten fan on shaft or replace fan</li> <li>- Replace fan wheels</li> </ul>
ELECTRICAL CONTROLS NOT WORKING WHEN DOOR IS OPEN	<ul style="list-style-type: none"> <li>- Switch is in off position</li> <li>- Door limit switch is not operating</li> </ul>	<ul style="list-style-type: none"> <li>- Turn unit's switch to the on position</li> <li>- Repair or replace door limit switch</li> </ul>
UNIT WILL NOT TURN OFF	<ul style="list-style-type: none"> <li>- Door limit switch is permanently closed or energized</li> </ul>	<ul style="list-style-type: none"> <li>- Position the door switch in a manner that turns off the unit when the door closes, and turns on the unit when the door opens. Only light pressure required.</li> </ul>
LOW AIR FLOW	<ul style="list-style-type: none"> <li>- Discharge air vanes out of adjustment</li> <li>- Obstruction on intake or discharge</li> <li>- Power leads out of polarity</li> <li>- Blower motor rotating below normal speed</li> <li>- Fan rubbing against housing</li> <li>- Blower wheels clogged with dirt</li> </ul>	<ul style="list-style-type: none"> <li>- Adjust vanes to proper position (Refer to Start-Up Section in this manual)</li> <li>- Remove obstruction or move air curtain</li> <li>- Switch power leads to correct polarity (3 phase models only)</li> <li>- Apply proper voltage per unit requirement (see unit label) / Adjust adjustable motor speed knob (if applicable)</li> <li>- Free fan from housing</li> <li>- Clean and remove dirt from blower wheels</li> </ul>
EXCESSIVE AIR VELOCITY AT DOOR OPENING	<ul style="list-style-type: none"> <li>- Nozzle out of adjustment and not angled far out enough (BD only)</li> <li>- Air temperature too cold</li> <li>- Air stream pushing air outside of the building</li> </ul>	<ul style="list-style-type: none"> <li>- Adjust nozzle angle to outside</li> <li>- Add auxiliary heat to overcome wind chill</li> <li>- Adjust discharge angle back into building</li> </ul>
AIR NOT HITTING THE FLOOR	<ul style="list-style-type: none"> <li>- Low air velocity</li> <li>- Obstruction in the direction of air flow</li> <li>- Negative building pressure</li> </ul>	<ul style="list-style-type: none"> <li>- Adjust vanes to proper position or check installation height (Refer to Start-Up Section in this manual)</li> <li>- Remove obstruction or move air curtain (Move out 3/8" for every 1" up from the door)</li> <li>- Provide a make-up air system to relieve negative building pressure</li> </ul>
UNEVEN AIR	<ul style="list-style-type: none"> <li>- Shaft rotating inside fan</li> <li>- One motor not functioning</li> </ul>	<ul style="list-style-type: none"> <li>- Replace fan or tighten fan on shaft</li> <li>- Replace or repair motor</li> </ul>
EXCESSIVE NOISE AND OR VIBRATION	<ul style="list-style-type: none"> <li>- Loose or broken coupling (belt drive)</li> <li>- Loose set screws on wheel hubs</li> <li>- Fan spinning inside fan housing</li> <li>- Broken fan hub</li> <li>- Bearing end caps worn</li> <li>- Damaged blower wheel</li> <li>- Bearing end caps worn</li> <li>- Balancing clips missing</li> </ul>	<ul style="list-style-type: none"> <li>- Replace or tighten coupling</li> <li>- Tighten set screws on motor shaft flats</li> <li>- Tighten fan on shaft or replace fan</li> <li>- Replace fan wheels</li> <li>- Replace Bearing end caps</li> <li>- Replace Blower Wheel</li> <li>- Replace Bearing end caps</li> <li>- Replace Blower Wheel</li> </ul>

## WARRANTY

Mars' warranty coverage, period, extent and limitations apply to the product only. It does not apply to labor. Mars warrants that Mars product 1) Is free from defects in materials and workmanship and 2) Conforms to Mars' published specifications. The warranty period for Mars product except heated and custom models, is a five (5) year period commencing on its date of shipment. The date on customer's invoice is the date of shipment, unless Mars or your reseller informs you and Mars otherwise. For heated and custom models, the warranty period is an eighteen (18) month period commencing the date of shipment. Mars will provide free replacement of any part that fails as a result of a defect in material or manufacturer's workmanship. Changes in operational specification parameters that are different from those provided on the original purchase order are not covered. Mars product is inspected and tested before packaging and is shipped in working condition. The warranty for Mars product only covers free-of-charge replacement of failed parts. The warranty does not cover labor and transportation expenses that may be required to provide and to install replacement parts. Because in many instances, it is impossible to determine the cause of failure, customer may be responsible for transportation charges associated with replacement of failed part. Mars does not warrant uninterrupted or error-free operation of Mars product. Under no circumstance is Mars liable for any of the following: 1) Third-party claims against you for damages; or 2) Special, incidental, or indirect damages or for any economic consequential damages (including lost profits and savings), even if Mars, its suppliers, or its reseller is informed of their possibility. The warranty does not cover repair or exchange of Mars product resulting from misuse, accident, modification, unsuitable physical or operating environment, improper maintenance and installation by customer, or failure caused by a product for which Mars is not responsible. The warranty does not cover damages caused by mishandling during transportation. The warranty is voided by removal or alteration of Mars product or parts identification labels, by improper installation of product, and resulting non-compliance to federal, state and local codes and regulations. Additionally, Mars reserves the right to void the warranty for non-payment of invoice.

**CONTACT FACTORY FOR COMPLETE PARTS LIST FOR ALL MODELS.**

**KEEP THIS MANUAL FOR YOUR RECORDS.**

**Model Number:** \_\_\_\_\_

**Serial Number:** \_\_\_\_\_

**Date Purchased:** \_\_\_\_\_

**Dealer Purchased From:** \_\_\_\_\_



**14716 S. Broadway St., Gardena, CA 90248**

**(310) 532-1555 • (800) 421-1266**

**Fax: (310) 324-3030**

**[www.marsair.com](http://www.marsair.com)**