

DLB-2 BLOWER (10,000 TO 14,000CFM)

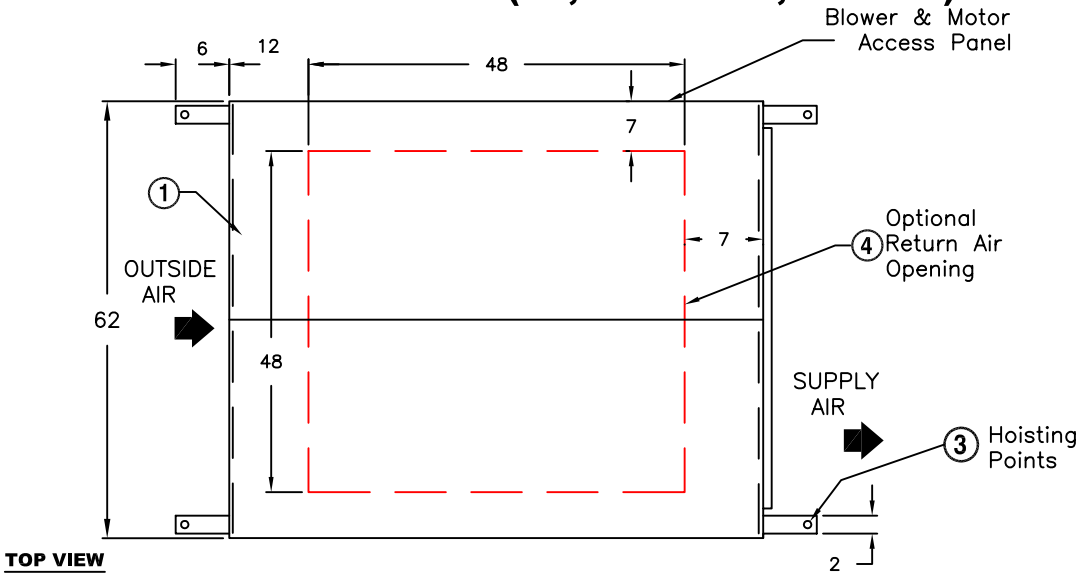

TOP VIEW

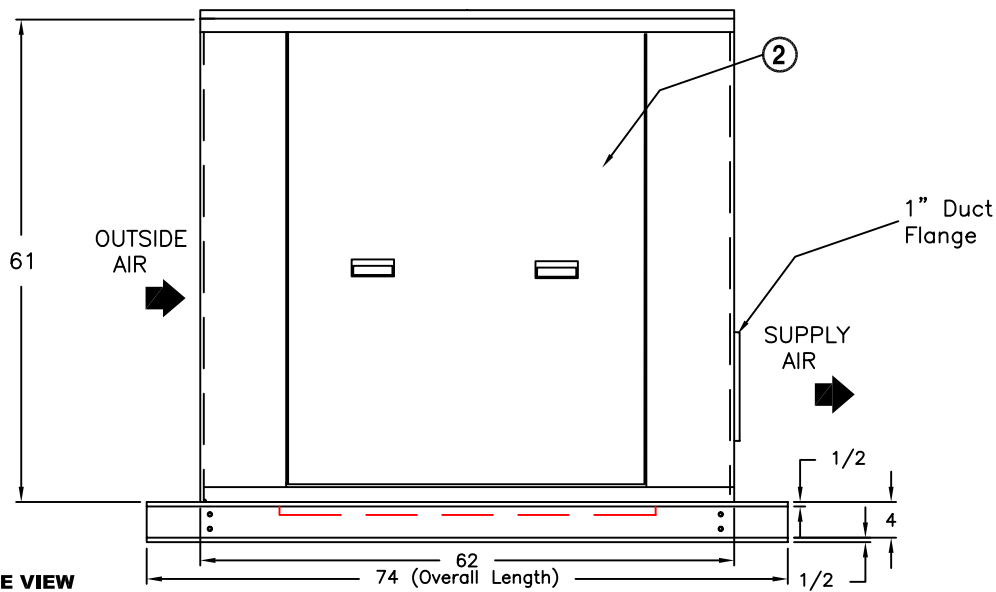

SIDE VIEW

NOTES:

- ① Base Unit Constructed of 18 Ga. G90. Galvanized Finish. Unit Option with (9) 18"x20"x2" PowerGard filters. Nominal 30% efficiency.
- ② Solid Blower & Motor Access Panels on both side of dual blower.
- ③ Hoisting Points are a part of the Unit Mounting Rails and are not intended for use in suspending units. Contact factory for unit suspending information. In addition, hoisting eyes will shipped loose for additional support.
- ④ Optional Return Air opening shown. Return Air Opening is 48" x 48". Return Air option includes (9) 16"x16"x1' T/A Filter as standard. R/A Max CFM is 10,400cfm.
- ⑤ Full perimeter rail 8 to 12 GA, G90, Galvanized finish with 6" lifting extensions. NOT intended for suspending unit, contact factory.

NOTE: ARES reserves the right to change specifications and product design without notice. Such revisions do not entitle the buyer to corresponding changes, improvements, additions or replacements for previously purchased equipment.

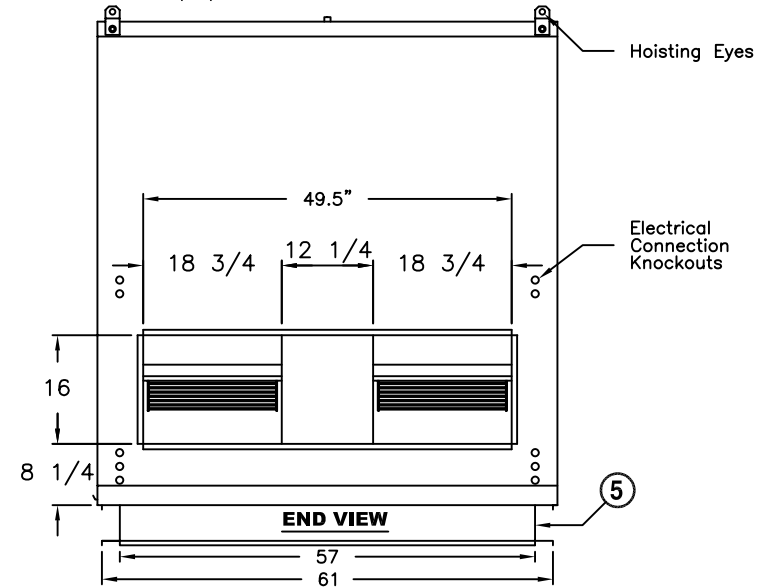

END VIEW

NOTE: All dimensions are in inches.

APPROX. NET WEIGHT: 650 lbs.

PROJECT:	LOCATION:	
ENGINEER:	ARCHITECT:	
CONTRACTOR:	DATE:	PAGE: _____ of _____

ARES
 A Division of Mars® Air Products
 14716 S. BROADWAY ♦ GARDENA, CA 90248
 Phone: (310) 532-1555 ♦ (800) 421-1266 ♦ Fax: (310) 324-3030
 WEB SITE: www.marsair.com ♦ E-MAIL: aresinfo@marsair.com

DLB-2, UNIT RAIL