

## HEATED PRODUCTS SUPPLEMENT

### NOTE

**Before proceeding, refer to the units specific IOM Manual for safety, installation and start information. Verify proper voltage to the product per local and NEC codes. Ensure proper rotation for units with three phase motors.**

### Electrically Heated Products

Electrically heated products must be mounted on the inside of the building. Electrically heated products come standard with a thermostat (provided and shipped loose, unless ordered as factory pre-mounted) and is to be field installed at eye level within 3 feet (1 M) of the unit.

#### Note:

1. Electrically heated Low Profile, Phantom, Standard2, High Velocity2 and Extra Power2 units come with internally mounted controls and comes with 24V control circuit as standard option (FIG. 1) except the Low Profile series that is available with an optional 24V controls with line voltage, 115V or 208-240V controls as typical offering.
2. Wiring connection for the electrically heated Low Profile units is at the top of the housing which can be accessed by removing the top cover plate while internal terminal blocks are provided for electrically heated Phantom, Standard2, High Velocity2 and Extra Power2 units.
3. Electrically heated Wind Stopping and WindGuard units include an electric heater control panel mounted on the right-hand side, as standard. Optional motor/unit control panel available, which includes a remote 24-volt thermostat with On/Off switch with terminals provided.

The thermostat should be mounted as close to the product's discharge air flow as possible in order to best sense the discharged air temperature around the door opening. Connect proper voltage to the product per local and NEC codes.

Thermal overload protection is built into the heater coil assembly/assemblies. In the event of an overload condition, electrical power will be disconnected from the heater coil. Upon diagnosing the problem, electrical power can be re-instated to the heater coil(s) by manually resetting the thermal overload lever(s) or buttons(s) located in the unit or panel.

To operate multiple units mounted side by side, utilizing a single door switch and single thermostat, a master/slave configuration is required. (FIG. 2)

For high ampacity units, new holes can be drilled to bring in electrical wires. Use appropriate bushing for new holes to protect wire casing. High temperature silicon wires would be recommended for main supply power.

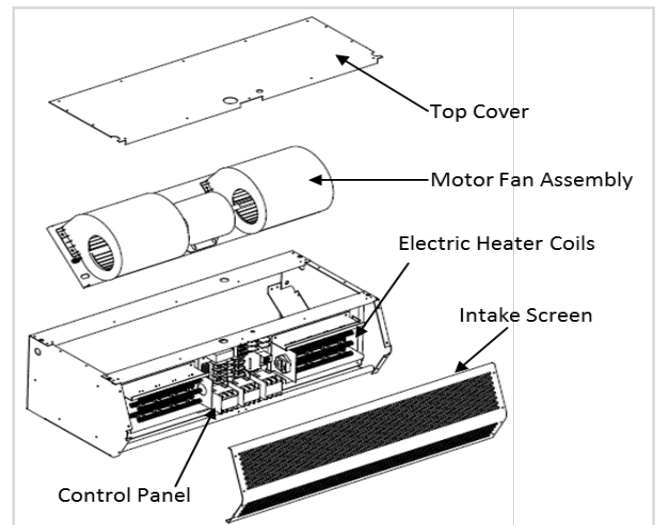

FIG. 1 (Electrically Heated STD2 unit)

Unobstructed clearance space of 18"-24" must be provided at the top of air curtain for performance and service for all heated air curtain.

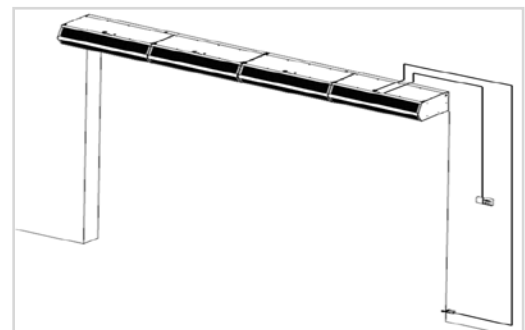

FIG. 2 (Tandem Mounted Master/Slave Units)

## Steam and Hot Water Coil Heated Products

Steam/Hot Water Coil (coil) heated products must be mounted on the inside of the building. The coil(s) for Low Profile, Standard, High Velocity, Extra Power and Phantom units are shipped internally mounted to the unit. Wind Stopping and WindGuard units are shipped with coil(s) factory mounted.

Once the coil has been secured to the cabinet, access to the motor and fan is through the removable access panels located on the top of the cabinet for Standard, High Velocity, Extra Power and Phantom units.

**Note:** Low Profile and Wind Stopping units require the removal of the coil to access the motor and/or fans.

All piping should be done by a licensed pipe fitter and in accordance with local codes and regulations. Connect the supply and return fittings as required. All traps and valves are sized and field-installed by others. For Standard, High Velocity and Extra Power units, front intake screen must be removed to access vent plugs. Standard coil configuration is right hand supply and left-hand return. (FIGS. 3 & 4) Optional temperature controls, if ordered, are to be field installed by others.

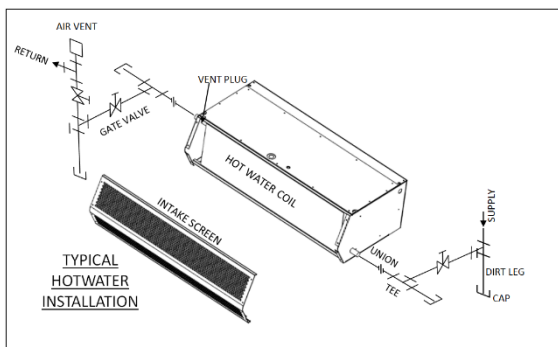

FIG. 3 (Hot Water Heated STD Unit)

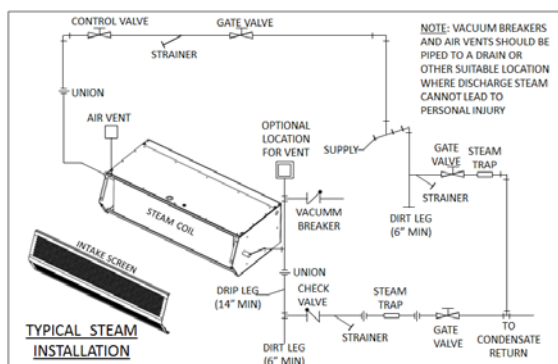

FIG. 4 (Steam Heated STD Unit)

## Gas Heated Products

Gas heated products must be mounted on the inside of the building. The product consists of three major components: the air curtain, transition section(s) and indirect gas fired duct furnaces(s) (FIG 5).

The transition section(s) are shipped knocked down and are to be field assembled and installed per their supplemental instructions. (FIG. 6) (Exceptions are WMI/H and BD series, fully assembled transitions are provided).

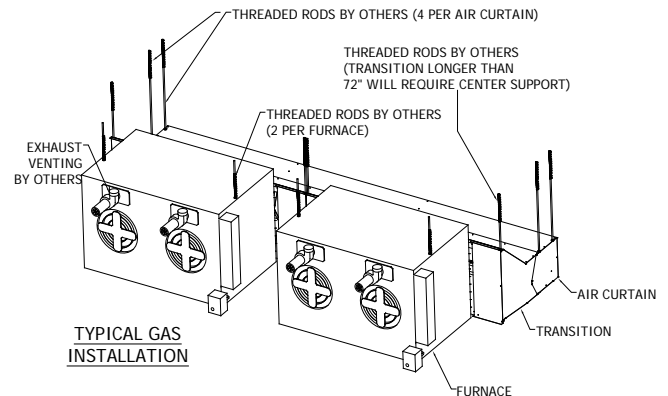

FIG. 5 (Indirect Fired Gas Heated HV Unit)

### Note:

1. Assemble the transition section(s).
2. Measure the width of the transition section(s) to determine the installation location for the duct furnace(s).
3. The duct furnace(s) are typically hung from above, with threaded rods, in order to support the weight of the duct furnaces. The duct furnace(s) must be centered and equally spaced with a 2" clearance between furnaces and the transition(s).
4. Move the adjustable blank off plates to close gaps in the transition(s) and secure the flanges to the transitions.

All gas piping and duct furnace(s) exhaust venting should be done by a licensed pipe fitter and in accordance with local codes and regulations. Power vented exhaust duct runs should not exceed 100' for horizontal venting. See furnace installation manual for piping and other details.

FIG. 6 (Transition Kit Exploded View)

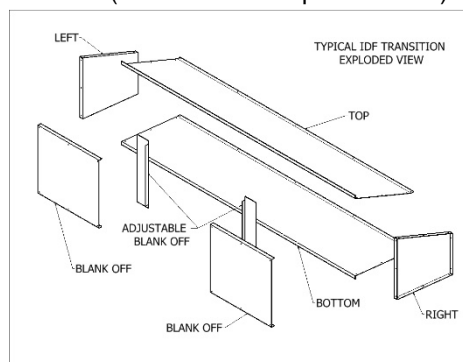

In the United States, installation must conform with local codes or, in the absence of local codes, with Installation of the National Fuel Gas Code, ANSI Z223.1-latest edition, from the American

National Standard Institute. Further reference should be made to the recommendation of your fuel supplier. In Canada, Installation must conform with local codes or, in the absence of local codes, with Installation Codes for Gas Burning Appliances and Equipment, CGA Standard CAN/CGA 1B-149. Further reference should be made to the recommendation of your fuel supplier.